Changing the Host Protocol in the E5600 or EF560 by Replacing Hardware Components

When you change the host protocol of an E5612, E5624, or E5660 storage array or an EF560 flash array by replacing hardware components, you must power off the storage array or flash array, remove hardware, install new hardware, and reapply power.

Before starting the procedure, be aware of the following:

- You must review the information in [Understanding the options for changing the host protocol](#) on page 2 to learn about the different methods for changing the host protocol and to confirm that you are using the correct instructions for your situation.
- Because the power must be off when you upgrade hardware to change the host protocol, you must schedule a downtime maintenance window for this procedure. You cannot access data on the storage array or flash array until you have successfully completed the upgrade.
- You must obtain any new cables, transceivers, switches, and host bus adapters (HBAs) needed for the new host protocol. You must install any new host hardware before you can connect the storage array or flash array to the hosts.

Attention: After installing the new hardware, you must inform NetApp technical support about the change to the hardware configuration by sending an upgrade notification. This notification ensures that you receive correct replacement parts if you need them later.

Steps

1. [Understanding the options for changing the host protocol](#) on page 2
2. [Determining the Replacement Part Number](#) on page 3
3. [Procedures for changing the host protocol](#) on page 3
4. [Managing Data Assurance](#) on page 6
5. [Managing Synchronous Mirroring](#) on page 7
6. [Managing Asynchronous Mirroring](#) on page 7
7. [Cabling considerations](#) on page 7
8. [Preparing to upgrade hardware](#) on page 8
9. [Powering down](#) on page 10
10. [Removing the controller canisters](#) on page 11
11. [Removing the HICs \(if upgrading only the HICs\)](#) on page 15
12. [Installing the new HICs \(if upgrading only the HICs\)](#) on page 16
13. [Replacing the controller canisters](#) on page 17
14. [Reconnecting the cables](#) on page 17
15. [Applying power](#) on page 17
16. [Restoring the drive security key \(if replacing controller canisters\)](#) on page 18
17. [After upgrading the hardware](#) on page 18
18. [Sending an upgrade notification to NetApp](#) on page 19

Related information

[NetApp E-Series and EF-Series Systems Documentation Center](#)

[NetApp Downloads](#)



[NetApp Interoperability Matrix Tool](#)

Understanding the options for changing the host protocol

Review the options for changing the host protocol in an E5600 storage array or an EF560 flash array to confirm that you are following the correct steps.

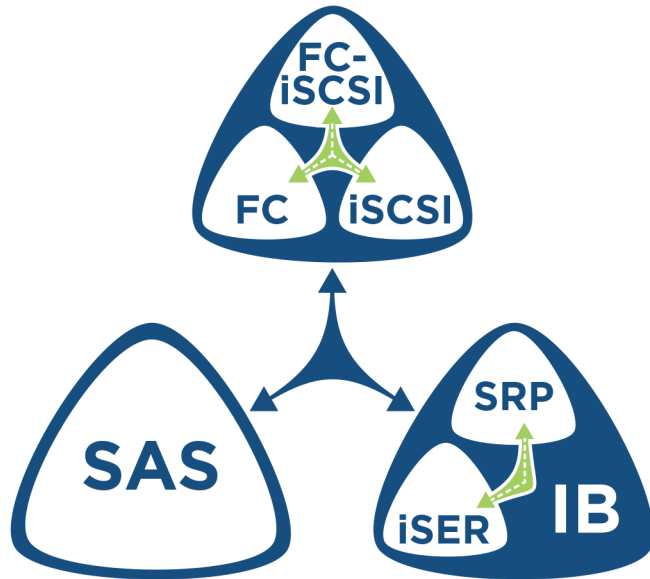
The following figure provides a high-level overview of the options for changing the host protocol of an E5600 storage array or an EF560 flash array.



Key	Option	Description
	Hardware upgrade	You must replace hardware to change the protocol. Note: For most hardware upgrades, you need to replace only the HICs; however, if you currently use iSCSI, Fibre Channel, or Fibre Channel-iSCSI split protocol, you might need to replace the controller canisters, which include the HICs. The exact procedure you need to follow depends on your Replacement Part Number. Refer to Determining the Replacement Part Number on page 3.
	Software feature pack conversion	You can apply a software feature pack in SANtricity Storage Manager to change the protocol. Important: This document does not describe how to perform software feature pack conversions. For those instructions, use one of the documents listed at the end of this topic.

As the figure indicates, there are three methods for changing the host protocol. You might need to:

- Upgrade hardware components (the paths shown with the solid, blue arrows)
- Perform a software feature pack conversion (the paths shown with the dotted, green arrows)
- Perform both a hardware upgrade and a feature pack conversion. For example, if you want to change the protocol from SAS to Infiniband (IB), and you want to use iSCSI RDMA Protocol (SRP) instead of iSCSI Extensions for Remote Direct Memory Access (iSER), you must follow a two-step process:

1. Upgrade the hardware to change the HICs from SAS to IB-iSER (this is the IB HIC's default protocol).

2. Perform a software feature pack conversion to convert the IB protocol from iSER to SRP.

Related information

[Converting a Fibre Channel Host Interface Card to iSCSI](#)

[Converting an iSCSI Host Interface Card to Fibre Channel](#)

[Converting a Fibre Channel Host Interface Card to Fibre Channel-iSCSI Split Mode](#)

[Converting an iSCSI Host Interface Card to Fibre Channel-iSCSI Split Mode](#)

[Converting a Host Interface Card from Fibre Channel-iSCSI Split Mode to Fibre Channel](#)

[Converting a Host Interface Card from Fibre Channel-iSCSI Split Mode to iSCSI](#)

[Converting an InfiniBand HIC from iSER to SRP](#)

Determining the Replacement Part Number

For most hardware upgrades to change the host protocol, you need to replace only the HICs. However, if you are currently using Fibre Channel (FC), iSCSI, or FC-iSCSI split protocol, you might need to replace the controller canisters, which include the HICs. The exact procedure you need to follow depends on your Replacement Part Number, which is displayed in SANtricity Storage Manager.

About this task

If you currently use FC, SCSI, or FC-iSCSI split protocol, follow these steps to locate the Replacement Part Number.

Note:

If you currently use SAS or IB protocol, you can skip this section.

Steps

1. In the **Array Management Window**, click the **Hardware** tab.
2. In the **Base Controller Properties** section, check the value for **Replacement Part Number**.
3. Look at the Replacement Part Number to determine whether you must upgrade both controller canisters or whether you can upgrade only the HICs:
 - If the Replacement Part Number is *E-X561206A-R6* or *EF-X561206A-R6*, you must replace the controller canisters, which include the HICs.
 - If the Replacement Part Number is any other value, you can remove the HICs from the existing controller canisters and install new HICs.

Procedures for changing the host protocol

Before changing the host protocol in your E5600 storage array or EF560 flash array, confirm that you understand the general steps.

The following tables provide an overview of each supported hardware upgrade procedure.

Table 1: Hardware upgrades from Fibre Channel, iSCSI, or FC-iSCSI

Starting protocol	Ending protocol	Procedure overview	For detailed instructions
FC, iSCSI or FC-iSCSI split mode	SAS	Hardware upgrade <ol style="list-style-type: none"> 1. Check the Replacement Part Number in SANtricity Storage Manager. 2. If that number is <i>E-X561206A-R6</i> or <i>EF-X561206A-R6</i>, replace both controller canisters with new controller canisters that include SAS HICs. If the Replacement Part Number is any other value, replace the old HICs with new SAS HICs. 	Complete the steps in Determining the Replacement Part Number on page 3, and then follow the applicable instructions in this document.
	IB-iSER	Hardware upgrade <ol style="list-style-type: none"> 1. Check the Replacement Part Number in SANtricity Storage Manager. 2. If that number is <i>E-X561206A-R6</i> or <i>EF-X561206A-R6</i>, replace both controller canisters with new controller canisters that include IB HICs. If the Replacement Part Number is any other value, replace the old HICs with new IB HICs. 	Complete the steps in Determining the Replacement Part Number on page 3, and then follow the applicable instructions in this document.
	IB-SRP	Hardware upgrade and conversion <ol style="list-style-type: none"> 1. Check the Replacement Part Number in SANtricity Storage Manager. 2. If that number is <i>E-X561206A-R6</i> or <i>EF-X561206A-R6</i>, replace both controller canisters with new controller canisters that include IB HICs. If the Replacement Part Number is any other value, replace the old HICs with new IB HICs. 3. Apply a feature pack to convert the IB HICs from iSER to SRP. 	Follow the instructions in this document, and then refer to Converting an InfiniBand HIC from iSER to SRP .

Table 2: Hardware upgrades from SAS

Starting protocol	Ending protocol	Procedure overview	For detailed instructions
SAS	IB-iSER	HIC upgrade 1. Remove the SAS HICs. 2. Install new IB HICs.	Follow the instructions in this document.
	IB-SRP	HIC upgrade and conversion 1. Remove the SAS HICs. 2. Install new IB HICs. 3. Apply a feature pack to convert the IB HICs from iSER to SRP.	Follow the instructions in this document, and then refer to <i>Converting an InfiniBand HIC from iSER to SRP</i> .
	FC	HIC upgrade 1. Remove the SAS HICs. 2. Install new FC HICs.	Follow the instructions in this document.
	iSCSI	HIC upgrade and conversion 1. Remove the SAS HICs. 2. Install new FC HICs. 3. Apply a feature pack to convert the FC HICs to iSCSI.	Follow the instructions in this document, and then refer to <i>Converting a Fibre Channel Host Interface Card to iSCSI</i> .
	FC-iSCSI split mode	HIC upgrade and conversion 1. Remove the SAS HICs. 2. Install new FC HICs. 3. Apply a feature pack to convert the FC HICs to FC-iSCSI split mode.	Follow the instructions in this document, and then refer to <i>Converting a Fibre Channel Host Interface Card to Fibre Channel-iSCSI Split Mode</i> .

Table 3: Hardware upgrades from IB

Starting protocol	Ending protocol	Procedure overview	For detailed instructions
IB (iSER or SRP)	SAS	HIC upgrade <ol style="list-style-type: none"> 1. Remove the IB HICs. 2. Install new SAS HICs. 	Follow the instructions in this document.
	FC	HIC upgrade <ol style="list-style-type: none"> 1. Remove the IB HICs. 2. Install new FC HICs. 	Follow the instructions in this document.
	iSCSI	HIC upgrade and conversion <ol style="list-style-type: none"> 1. Remove the IB HICs. 2. Install new FC HICs. 3. Apply a feature pack to convert the FC HICs to iSCSI. 	Follow the instructions in this document, and then refer to Converting a Fibre Channel Host Interface Card to iSCSI .
	FC-iSCSI split mode	HIC upgrade and conversion <ol style="list-style-type: none"> 1. Remove the IB HICs. 2. Install new FC HICs. 3. Apply a feature pack to convert the FC HICs to FC-iSCSI split mode. 	Follow the instructions in this document, and then refer to Converting a Fibre Channel Host Interface Card to Fibre Channel-iSCSI Split Mode .

Managing Data Assurance

If you are currently using the Data Assurance (DA) feature and want to change the protocol to iSCSI or IB-SRP, you must disable this feature on all volumes.

Steps

1. From the Array Management Window, select a volume, and then select **Storage > Volume > Advanced > Disable Data Assurance (DA)**.
2. In the **Volumes with Data Assurance (DA)** list box, select all volumes.

You must permanently disable the Data Assurance feature on all volumes. In addition, you cannot select volume groups in this list, only individual volumes.

3. Click **Disable**.

The **Confirm Disable Data Assurance** dialog box is displayed.

4. In the **Are you sure you want to disable Data Assurance on the selected volumes** field, type **yes**.
5. Click **OK**.
6. For each data volume or disk pool, confirm that Data Assurance has been disabled.

Managing Synchronous Mirroring

The Synchronous Mirroring feature (also referred to as RVM) is supported only for Fibre Channel.

About this task

If you are currently using Synchronous Mirroring and want to change from Fibre Channel to any other protocol, you must delete any synchronous mirrored pairs and deactivate any synchronous mirroring relationships.

Attention: If you do not deactivate these relationships before upgrading the HICs, your system loses data access and data loss might occur.

Steps

1. In the **Array Management Window**, select **Help > Contents**, and search for the topics related to Synchronous Mirroring.
2. Follow the instructions in the online help to identify all synchronous mirroring volumes that might exist.
3. In the Logical pane, right-click a synchronous mirroring volume, and select **Copy Services > Synchronous Mirroring > Remove Mirror Relationship**.
4. Select all volumes, and click **Remove**.
5. After you delete all mirroring relationships, deactivate Synchronous Mirroring by selecting **Copy Services > Mirroring > Deactivate**.
6. Select the **synchronous mirroring** check box from the pop-up window.

Attention: If you do not delete all mirroring relationships before deactivating mirroring, you receive an error.

Managing Asynchronous Mirroring

The Asynchronous Mirroring feature (also referred to as ARVM) is supported only for iSCSI and Fibre Channel.

About this task

If you are currently using asynchronous mirroring relationships and want to change the protocol to IB or SAS, you must delete the mirrored pairs and deactivate the asynchronous mirroring relationships.

Steps

1. In the **Array Management Window**, access the online help and search for the topics related to Asynchronous Mirroring.
2. Follow the instructions in the online help to remove all asynchronous mirrored pairs from the asynchronous mirror groups.
Note: When removing each pair, select the **Delete all repositories associated with this mirrored pair** check box.
3. Follow the instructions in the online help to delete all asynchronous mirror groups.

Cabling considerations

Before upgrading hardware, confirm that your replacement cables and any SFPs or QSFPs are compatible with the connectors on the new HICs.

The following table lists the supported cables for E5600 and EF560 HICs:

HIC		Cable		
Data rate and protocol	Number of connectors	Connector	Type	Length
16 Gbps Fibre Channel	4	SFP+	OM2 SW optical	2, 3, 5, 10, 25m
		SFP+	OM3 SW optical	50-150m
		SFP+	OS2 LW optical	50-300m
12 Gbps SAS	4	MiniSAS-HD	Passive copper	1-5m
		MiniSAS-HD	Active copper	8-15m
		MiniSAS-HD	Optical	5-100m
		Fan-out cable type #2	Passive copper	2m
		Fan-out cable type #3	Passive copper	2m
56 Gbps InfiniBand	2	QSFP+	Passive copper	1-3m
		QSFP+	Optical	5-100m
10 Gbps iSCSI	4	SFP+	OM2 optical	2, 3, 5, 10, 25m
		SFP+	OM3 optical	50-150m
		Twin-Ax	Passive copper	2-7m
1 Gbps iSCSI		RJ-45	Passive copper	2-70m

Preparing to upgrade hardware

You must perform a number of steps to prepare your system for changing the host protocol by upgrading hardware, including stopping host I/O operations, issuing a CLI command to remove any previously applied software feature packs, and saving the chassis serial number. If you use the Drive Security feature and you are replacing controller canisters, you also must save the drive security key.

Before you begin

- If you are changing the protocol to iSCSI or IB-SRP, you must have disabled Data Assurance on all volumes.
- If you were using Asynchronous Mirroring or Synchronous Mirroring, you have deleted all mirrored pairs and deactivated all mirroring relationships, where applicable.

Steps

1. Gather support data about your storage array by using one of these methods:
 - Use the storage management software to collect and save a support bundle of your storage array. From the Array Management Window toolbar, select **Monitor > Health > Collect Support Data Manually**. Then, name and specify a location on your system where you want to store the support bundle.
 - Use the command-line interface (CLI) to run the `save storageArray supportData` command. From the Enterprise Management Window, select the storage array, and select **Tools > Execute Script**. In the Script Editor dialog box, enter the following command, and select **Tools > Verify and Execute** from the menu:

```
save storageArray supportData;
```

Note: Gathering support data can temporarily impact performance on your storage array.

2. Ensure that no I/O operations are occurring between the storage array and all connected hosts. For example, you can perform these steps:

- Stop all processes that involve the LUNs mapped from the storage to the hosts.
- Ensure that no applications are writing data to any LUNs mapped from the storage to the hosts.
- Unmount all file systems associated with volumes on the array.

Note: The exact steps to stop host I/O operations depend on the host operating system and the configuration, which are beyond the scope of these instructions. If you are not sure how to stop host I/O operations in your environment, consider shutting down the host.

Attention: Possible data loss – If you continue this procedure while I/O operations are occurring, you might lose data.

3. If the storage array participates in a mirroring relationship, stop all host I/O operations on the secondary storage array.

4. Wait for five minutes to allow any data in cache memory to be flushed to disk.

5. From the title bar of the **Array Management Window**, select **Monitor > Reports > Operations in Progress**.

6. Wait for all operations shown on the **Operations in Progress** window to complete before continuing with the next step.

7. Follow these steps to disable any feature packs that might have been applied to the storage array in manufacturing or after you received the system:

a. From the **Enterprise Management Window** in SANtricity Storage Manager, select the storage array.

b. Select **Tools > Execute Script**.

The Script Editor dialog box is displayed.

c. Type the following command:

```
disable storageArray featurePack;
```

d. From the menu, select **Tools > Verify and Execute**.

The command syntax is verified, and the command is executed.

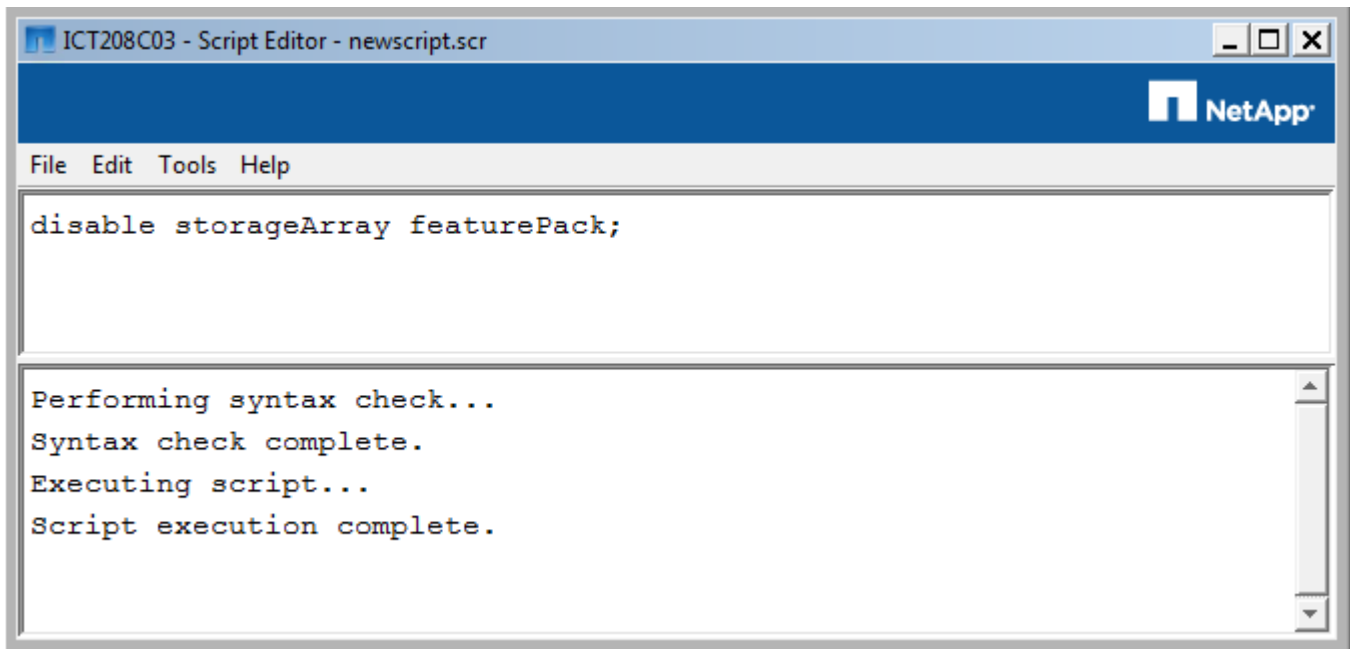

8. Record the chassis serial number for your storage array, as follows:

Note: You must have this number to send an upgrade notification to NetApp technical support indicating that you have changed the configuration.

- a. In the **Enterprise Management Window** tree view, double-click your storage array.
 - b. In the **Summary** tab of the **Array Management Window**, click the **View Storage Array Profile** link.
 - c. Copy the value for **Chassis Serial Number**, and paste it into a text file.
9. If you are using the Drive Security feature and you are replacing the controller canisters, follow these steps to save the drive security key:
- a. Go to the **Array Management Window**.
 - b. From the **Storage Array** menu, select **Security > Drive Security > Save Key**.
 - c. Save the security key to a location not on your storage array.

Powering down

After preparing to upgrade the hardware, you can power down the storage array or flash array.

Before you begin

- You must have collected a support bundle.
- You must have stopped host I/O operations and confirmed that no operations are in process.
- You must have removed all feature packs.
- You must have saved the chassis serial number to a file.

- If you are using the Drive Security feature and you are replacing the controller canisters, you must have saved the drive security key.

Steps

1. Turn off both power switches on the controller-drive tray.
2. Wait for all LEDs on the controller-drive tray to go dark.
3. Turn off both power switches on any attached expansion drive trays.
4. Wait two minutes for drive activity to stop.

Removing the controller canisters

The controller canisters contain the controllers, HICs, and batteries. When you upgrade hardware to change the host protocol, you must remove both controller canisters from the controller-drive tray or flash array.

Before you begin

You must have an ESD wristband or have taken other antistatic precautions.

About this task

If you are upgrading only the HICs, you must remove the controller canisters to access the HICs. If you are replacing the controller canisters, you must remove the original controller canisters and their batteries, so you can use the batteries in the new controller canisters.

Steps

1. Put on antistatic protection.
 - Attention: Possible hardware damage** – To prevent electrostatic discharge damage, use proper antistatic protection when handling tray components.
2. Label each cable that is attached to the controller canisters.

Labels make it easier to replace the host cables and to reconnect the management cables and any drive cables.
3. Disconnect all cables from the controller canisters.

If fiber-optic cables are present, use the two release levers to partially remove the controller canister. Opening these release levers makes it easier to press down the fiber-optic cable release tab.

 - Attention: Potential degraded performance** – To prevent degraded performance, do not twist, fold, pinch, or step on the cables.
4. Follow these steps to remove controller A:
 - a. Unlock and rotate the release handles out to release the controller canister.
 - b. Using the release handles and your hands, pull the controller canister out of the tray.

Removing a controller canister from an E5612, E5624, or EF560 tray

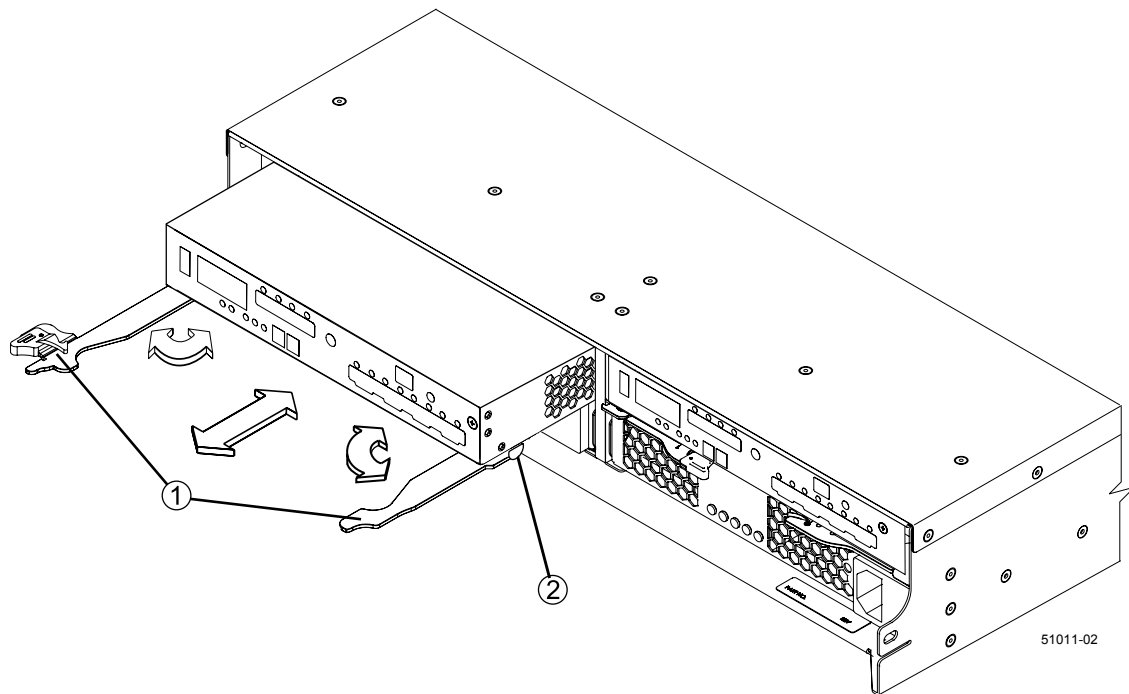

1	Release handles
2	Controller canister

Removing a controller canister from an E5660 controller-drive tray

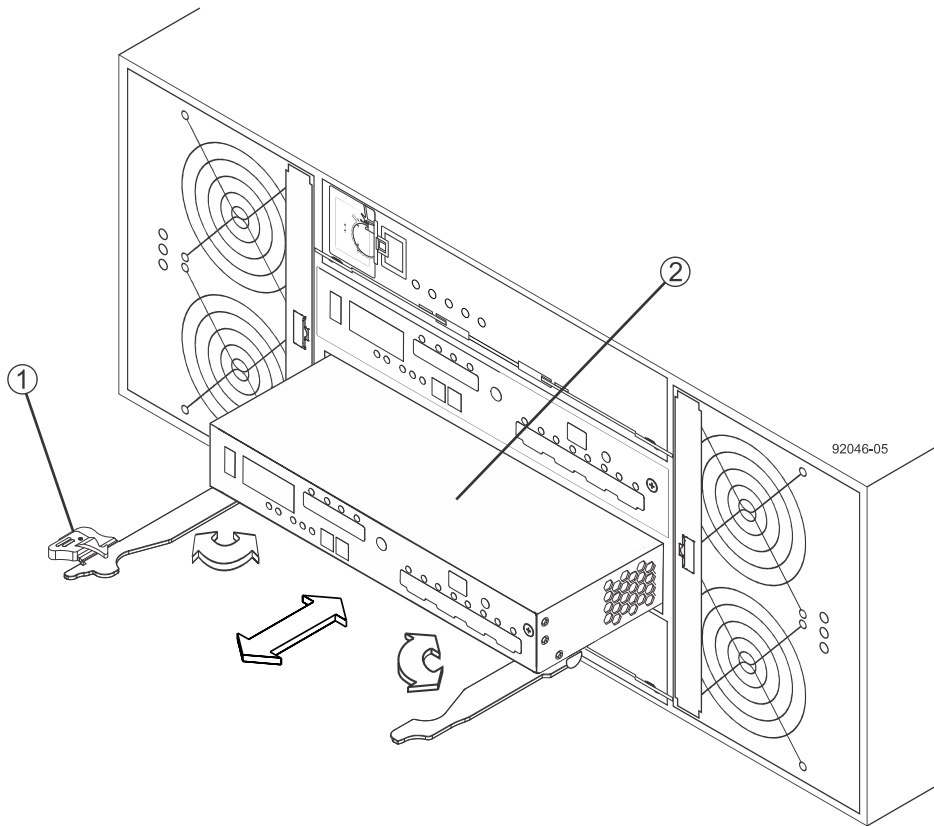

1	Release handles
2	Controller canister

5. Set the controller canister on a flat, static-free surface.
6. Repeat these steps to remove controller B.
7. Determine if you need to remove the batteries as follows:
 - If you are upgrading only the HICs, you will reuse the controller canisters, so you do not need to remove the batteries. Go to [Removing the HICs \(if upgrading only the HICs\)](#) on page 15.
 - If you are replacing the controller canisters, you must remove the batteries from the original controller canisters and install them into the new controller canisters, as described in the next section.

Removing and replacing the battery (if replacing controller canisters)

If you are replacing both controller canisters (instead of upgrading only the HICs), you must remove the batteries from the original controller canisters and install them into the new controller canisters.

Before you begin

You have reviewed [Procedures for changing the host protocol](#) on page 3 and determined that you must replace both controller canisters.

Steps

1. Follow these steps to remove the battery from the controller canister A:

- a. Press down on both of the top-cover latch buttons, and slide the top cover off the controller canister.
- b. Release the tab that secures the battery to the controller canister.

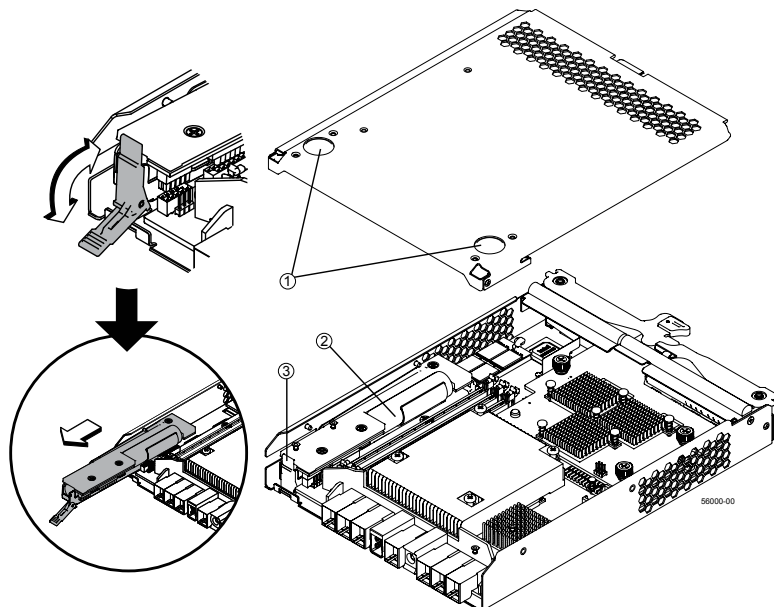

1	Top-cover latch buttons
2	Battery
3	Locking tab

- c. Remove the battery by sliding it towards the rear of the controller canister.
- d. Repeat these steps for controller B.

2. Follow these steps to install the batteries into the new controller canisters:

- a. Unpack the new controller canister, and set it on a flat, static-free surface with the top cover up. Save the packing materials in case you need to return the old controller canisters.
- b. Press down on both of the top-cover latch buttons, and slide the top cover off the controller canister.
- c. Insert the battery at a slight downward angle into the controller canister.
- d. Slide the battery into the canister, making sure it stays below the rivets on the wall of the canister.
- e. Keeping the locking handle at a 45-degree angle, align the connectors at the bottom of the battery with the connectors on the canister.
- f. Push the battery down until you hear it click, and move the locking handle up to secure the battery to the controller canister.

Attention: To make sure that the battery is seated correctly, you might need to slide it out and insert it again. You know it is secure when you hear it click into place and when the locking handle does not move out of its upright position when you wiggle it.

- g. Repeat these steps for the second controller canister.

3. Go to [Replacing the controller canisters](#) on page 17.

Removing the HICs (if upgrading only the HICs)

If you are upgrading the HICs (instead of replacing the controller canisters), you must remove the HICs from both controller canisters before you can upgrade the host protocol.

Before you begin

You must have an ESD wristband or have taken other antistatic precautions.

Steps

1. Remove the top cover from controller A.
Press down on both the top-cover latch buttons, and slide the top cover to the rear.
2. Remove the four screws for the HIC faceplate using a Phillips screwdriver, and remove the faceplate from the controller canister.
3. Unscrew the three thumbscrews that secure the HIC to the controller card.
If the thumbscrews are overly tightened, use a Phillips screwdriver.
4. Detach the HIC from the controller card by lifting it up and gently sliding back.

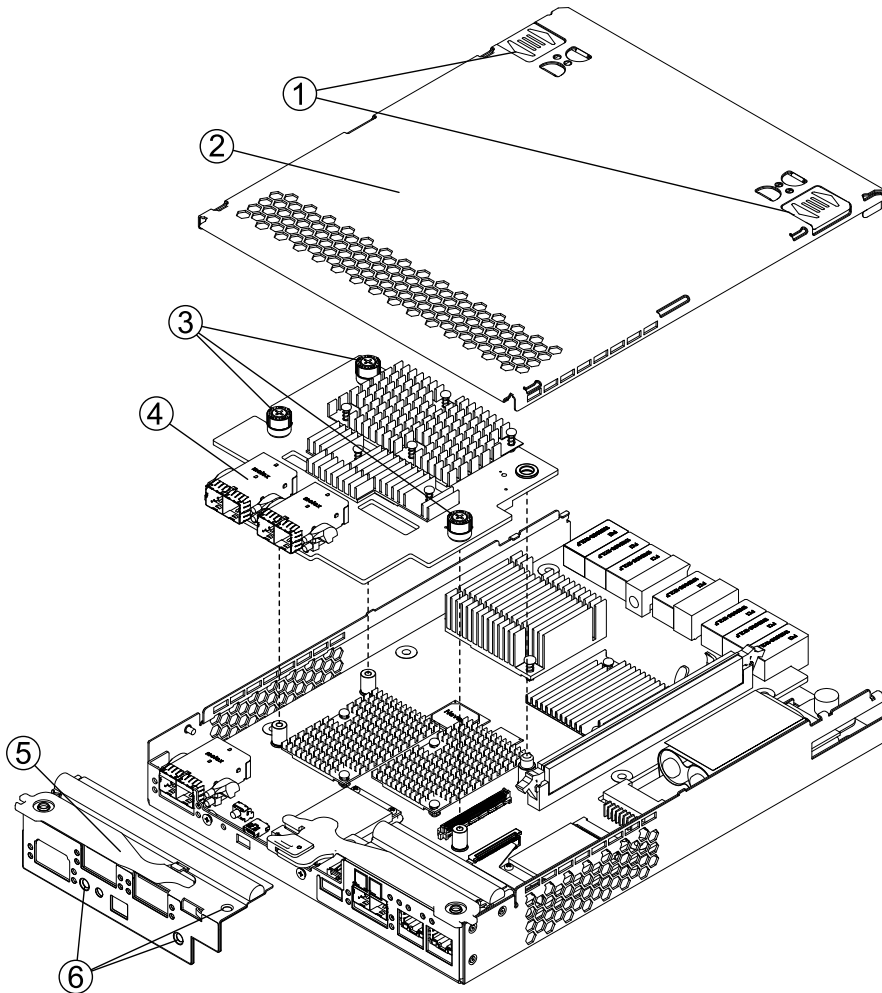

1	Top-cover latch buttons
2	Top cover
3	Thumbscrews
4	Host interface card
5	Faceplate
6	Faceplate screws

- Place the HIC in an antistatic bag.
- Repeat these steps to remove the HIC from controller B.

Installing the new HICs (if upgrading only the HICs)

After removing the original HICs, you can install the new HICs and the new HIC faceplates.

Steps

- Unpack the new HICs and HIC faceplates.
- Write down the part number printed on the controller field-replaceable unit (FRU) label, which is located in the upper-left corner of the faceplate.

You need this number for the last step of this procedure when you send an upgrade notification to NetApp technical support. The upgrade notification alerts NetApp that you have changed the HIC protocol and helps to ensure that you receive correct replacement parts if you need them later.

The figure shows the location of the FRU label on the faceplate for an IB HIC.

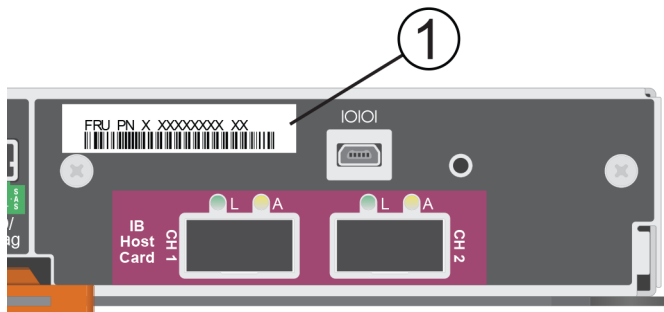

1	FRU label
---	-----------

- Gently connect the new HIC to the HIC interface connector on the controller card in controller A.

Note: Be careful not to scratch or bump the components on the bottom of the HIC or on the top of the controller card.
- Hand-tighten the three HIC thumbscrews.

If you use a screwdriver, you might overtighten the screws.
- Attach the HIC faceplate to the controller canister by replacing the four screws and tightening them with a Phillips screwdriver.
- Repeat these steps to install a HIC in controller B.

Replacing the controller canisters

You must replace the controller canisters before you can reconnect cables to the controller and HICs.

Steps

1. Reinstall the top cover on controller A by sliding it forward until the top cover latch buttons click.
2. Slide the controller canister all the way into the controller-drive tray or flash array.
3. Rotate the release levers towards the center of the controller canister to lock it into place.
4. Repeat these steps for controller B.

Reconnecting the cables

After you replace the controller canisters in the controller-drive tray or flash array, you can reconnect cables to the controller and HICs.

Before you begin

Verify that you have installed the appropriate host bus adapters (HBAs) in your host.

Steps

1. As needed, install SFP+ or QSFP transceivers into the new HIC ports.
2. Connect cables between HIC ports and the hosts.
3. Reconnect the cables between the controller-drive tray and any expansion drive trays.
4. Reconnect the cables between the management ports and the management station.
5. Reconnect the power cords to each controller canister.

Applying power

After replacing the controller canisters and reconnecting the cables, you can apply power to the E5600 storage array or EF560 flash array.

Steps

1. If you have expansion drive trays, turn on the two power switches at the back of each tray.
2. Wait two minutes.
3. Turn on the two power switches at the back of the controller-drive tray.
 - Do not turn off the power switches during the power-on process.
 - The fans in each tray are very loud when they first start up. The loud noise during start-up is normal.
4. Wait 10 minutes for the power-on process to complete.
5. Confirm that none of the amber LEDs on the front or back of any trays are illuminated.

Note: If an amber LED is on, there is a problem with a component. Use SANtricity Storage Manager to help resolve the problem.

6. Depending on the type of hardware upgrade you performed, do one of the following:
 - If you replaced only the HICs, go to [After upgrading the hardware](#) on page 18.
 - If you replaced the controller canisters and you use the Drive Security feature, you must restore the drive security key. Go to [Restoring the drive security key \(if replacing controller canisters\)](#) on page 18.

Restoring the drive security key (if replacing controller canisters)

If you are using the Drive Security feature and you replaced the controller canisters, you must restore the drive security key.

Steps

1. If the storage array includes a mix of secured and unsecured drives, create a new Drive Security key. (From the **Storage Array** menu, select **Security > Drive Security > Create Key**.)

Unsecured drives are unassigned drives, Global Hot Spare (GHS) drives, or drives that are part of a volume group or a disk pool that is not secured by Drive Security. Secured drives are assigned drives that are a part of a secured volume group or disk pool using Drive Security.

2. Import the Drive Security key you saved when preparing to remove the controllers. (From the **Storage Array** menu, select **Security > Drive Security > Import Key**.)

If the storage array has only secured drives (no unsecured drives), the controllers automatically reboot to complete the import operation.

3. Wait for the controllers to boot up.

When a controller finishes booting, its icon appears in the Enterprise Management Window (EMW).

4. If the Drive Security feature is enabled, and the storage array has a mix of secured and unsecured drives, follow these steps:
 - a. Run the `set allDrives nativeState SMcli` command.
 - b. Reset all controllers using SANtricity Storage Manager.
 - c. Wait for all controllers to boot up. When a controller has finished booting, its icon appears in the EMW.

After upgrading the hardware

After upgrading the hardware to change the host protocol, you must perform any additional steps for the new protocol.

Steps

1. Download the appropriate *SANtricity Express Guide* for the new host protocol.
2. Follow the instructions in the Express Guide to perform additional steps.

You might need to perform the following steps:

- Update the host mappings to replace the host ports.
- Configure the controller's iSCSI settings.

Related information

[SANtricity Storage Manager 11.25 Express Guide for Linux and Fibre Channel](#)

SANtricity Storage Manager 11.25 Express Guide for VMware and Fibre Channel
SANtricity Storage Manager 11.25 Express Guide for Windows and Fibre Channel
SANtricity Storage Manager 11.25 Express Guide for Linux and InfiniBand
SANtricity Storage Manager 11.25 Express Guide for Linux and SAS
SANtricity Storage Manager 11.25 Express Guide for VMware and SAS
SANtricity Storage Manager 11.25 Express Guide for Windows and SAS
SANtricity Storage Manager 11.25 Express Guide for Linux and iSCSI
SANtricity Storage Manager 11.25 Express Guide for VMware and iSCSI
SANtricity Storage Manager 11.25 Express Guide for Windows and iSCSI

Sending an upgrade notification to NetApp

Whenever you upgrade the HICs or controller canisters in your E5600 storage array or EF560 flash array, you must notify NetApp technical support. The upgrade notification alerts NetApp that you have changed the configuration and helps to ensure that you receive correct replacement parts if you need them later.

Before you begin

- You have obtained the chassis serial number for the controller-drive tray or the flash array.
- If you upgraded only the HICs, you have obtained the new FRU part number from the controller FRU labels on the HIC faceplates.

Steps

1. Go to the Give Us Feedback page on the NetApp Support Site.

[NetApp Support: Give Us Feedback](#)

2. Log in to the site.

The **Give Us Feedback** page is displayed.

Note: If the **Give Us Feedback** page is not displayed automatically, select **Contact Us > Report an Issue** from the top menu bar.

3. Enter your name and email address.

4. From the **Category 1** drop-down list, select **Product Registration**.

5. Depending on the type of hardware upgrade, perform one of the following steps:

- If you replaced the controller canisters, copy and paste the following text into the **Comments** text box. Replace <serial number> with the chassis serial number.

```
Create an alert against Serial Number: <serial number>. The alert name should be "E-Series Upgrade." The alert text should read as follows: "Attention: The controllers in this system have been upgraded from the original configuration. Verify the controller configuration before ordering replacement controllers and notify dispatch that the system has been upgraded."
```

- If you replaced only the HICs, copy and paste the following text into the **Comments** text box. Replace <serial number> with the chassis serial number. Replace <FRU part number> with the number you copied from the controller FRU label on the new HIC faceplates.

```
Create an alert against Serial Number: <serial number>. The alert name should be "E-Series Upgrade." The alert text should read as follows: "Attention: The HICs in this system have been upgraded from the original configuration. The new controller FRU
```

number is <FRU part number>. Verify the configuration before ordering replacement controllers and notify dispatch that the system has been upgraded."

6. Click **Submit**.

Copyright information

Copyright © 1994–2016 NetApp, Inc. All rights reserved. Printed in the U.S.

No part of this document covered by copyright may be reproduced in any form or by any means—graphic, electronic, or mechanical, including photocopying, recording, taping, or storage in an electronic retrieval system—without prior written permission of the copyright owner.

Software derived from copyrighted NetApp material is subject to the following license and disclaimer:

THIS SOFTWARE IS PROVIDED BY NETAPP "AS IS" AND WITHOUT ANY EXPRESS OR IMPLIED WARRANTIES, INCLUDING, BUT NOT LIMITED TO, THE IMPLIED WARRANTIES OF MERCHANTABILITY AND FITNESS FOR A PARTICULAR PURPOSE, WHICH ARE HEREBY DISCLAIMED. IN NO EVENT SHALL NETAPP BE LIABLE FOR ANY DIRECT, INDIRECT, INCIDENTAL, SPECIAL, EXEMPLARY, OR CONSEQUENTIAL DAMAGES (INCLUDING, BUT NOT LIMITED TO, PROCUREMENT OF SUBSTITUTE GOODS OR SERVICES; LOSS OF USE, DATA, OR PROFITS; OR BUSINESS INTERRUPTION) HOWEVER CAUSED AND ON ANY THEORY OF LIABILITY, WHETHER IN CONTRACT, STRICT LIABILITY, OR TORT (INCLUDING NEGLIGENCE OR OTHERWISE) ARISING IN ANY WAY OUT OF THE USE OF THIS SOFTWARE, EVEN IF ADVISED OF THE POSSIBILITY OF SUCH DAMAGE.

NetApp reserves the right to change any products described herein at any time, and without notice. NetApp assumes no responsibility or liability arising from the use of products described herein, except as expressly agreed to in writing by NetApp. The use or purchase of this product does not convey a license under any patent rights, trademark rights, or any other intellectual property rights of NetApp.

The product described in this manual may be protected by one or more U.S. patents, foreign patents, or pending applications.

RESTRICTED RIGHTS LEGEND: Use, duplication, or disclosure by the government is subject to restrictions as set forth in subparagraph (c)(1)(ii) of the Rights in Technical Data and Computer Software clause at DFARS 252.277-7103 (October 1988) and FAR 52-227-19 (June 1987).

Trademark information

NetApp, the NetApp logo, Go Further, Faster, AltaVault, ASUP, AutoSupport, Campaign Express, Cloud ONTAP, Clustered Data ONTAP, Customer Fitness, Data ONTAP, DataMotion, Fitness, Flash Accel, Flash Cache, Flash Pool, FlashRay, FlexArray, FlexCache, FlexClone, FlexPod, FlexScale, FlexShare, FlexVol, FPolicy, GetSuccessful, LockVault, Manage ONTAP, Mars, MetroCluster, MultiStore, NetApp Insight, OnCommand, ONTAP, ONTAPI, RAID DP, RAID-TEC, SANtricity, SecureShare, Simplicity, Simulate ONTAP, Snap Creator, SnapCenter, SnapCopy, SnapDrive, SnapIntegrator, SnapLock, SnapManager, SnapMirror, SnapMover, SnapProtect, SnapRestore, Snapshot, SnapValidator, SnapVault, StorageGRID, Tech OnTap, Unbound Cloud, and WAFL and other names are trademarks or registered trademarks of NetApp, Inc., in the United States, and/or other countries. All other brands or products are trademarks or registered trademarks of their respective holders and should be treated as such. A current list of NetApp trademarks is available on the web at <http://www.netapp.com/us/legal/netapptmlist.aspx>.

How to send comments about documentation and receive update notifications

You can help us to improve the quality of our documentation by sending us your feedback. You can receive automatic notification when production-level (GA/FCS) documentation is initially released or important changes are made to existing production-level documents.

If you have suggestions for improving this document, send us your comments by email to doccomments@netapp.com. To help us direct your comments to the correct division, include in the subject line the product name, version, and operating system.

If you want to be notified automatically when production-level documentation is released or important changes are made to existing production-level documents, follow Twitter account @NetAppDoc.

You can also contact us in the following ways:

- NetApp, Inc., 495 East Java Drive, Sunnyvale, CA 94089 U.S.
- Telephone: +1 (408) 822-6000
- Fax: +1 (408) 822-4501
- Support telephone: +1 (888) 463-8277