



System Cabinets

42U 1280 mm System Cabinet Guide

September 2018 | 215-12157_CO
doccomments@netapp.com

Contents

Preparing to install the system cabinet	4
System cabinet features	4
Required tools and equipment	6
Space requirements and system cabinet dimensions	6
Supported PDU types and specifications	8
Unpacking the system cabinet	9
Installing a system cabinet	10
Installing the cabinet interconnect kit	10
Installing the bolt-down kit	15
Installing additional support rails	16
Installing equipment in the system cabinet	18
Powering on the system cabinet	19
Replacing PDUs	21
Reversing the system cabinet front door	22
Removing the illuminated badge	23
Removing the system cabinet door	24
Moving the badge power supply and cabling	24
Reversing the door hinge and lock catch	27
Reinstalling the door and illuminated badge	29
Reinstalling the system cabinet door	29
Reinstalling the illuminated badge	30
Copyright information	31
Trademark information	32
How to send comments about documentation and receive update notifications	33
Index	34

Preparing to install the system cabinet

Before installing the system cabinet, you should familiarize yourself with its features. You must also verify that your site can support the system cabinet, move it to the desired location, and then unpack it.

System cabinet features

The system cabinet consists of side panels, front and rear doors, an optional bolt-down kit, an optional interconnect kit, PDUs for your equipment, and an integrated cable management system.

Feature	Description
Side panels	System cabinets have lockable, removable, and interchangeable side panels.
Perforated front and rear doors	System cabinets have removable front and rear doors with a quick release mechanism. The front door is reversible, and the rear doors are split. Both doors are perforated for cooling.
Common key	This key unlocks the front doors, rear doors, and side panels.
Spares kit	This kit is inside the system cabinet, attached to the cabinet door. It contains the following components: <ul style="list-style-type: none"> • Four 10-32 x 0.75 inch Phillips pilot screws • Four 10-32 cage nuts • One cage nut insertion tool • Two master key copies
Cable access	Cable pass-throughs are built into the top and bottom of the cabinet, as well as between the bottom of the rear door and the frame.
Cable management	Cable management hook and loop strapping is attached to the frame of the system cabinet at equal intervals.
Support rails	The number of support rails you receive depends on your configuration. The empty system cabinet is shipped with no support rails installed. <ul style="list-style-type: none"> • For configured system cabinets, one fixed rail kit is shipped with the system cabinet to support the 80xx, FAS8200, and DS4486 rear hold-down brackets. • Quick-ship system cabinets do not include the additional fixed rail kit.

Feature	Description
Blanking panels	<p>The number and size of blanking panels you receive depends on your configuration. The empty system cabinet is shipped with no blanking panels installed.</p>
Bolt-down kit	<p>This optional kit enables you to secure the system cabinet to the data center floor. The kit it is not intended for seismic stability.</p> <ul style="list-style-type: none"> • Four bolt-down brackets • Four spacer brackets • Six M8x20 mm hex head bolts and washers
Interconnect kit	<p>This optional kit enables you to connect multiple system cabinets to each other.</p> <ul style="list-style-type: none"> • Interconnect brackets <ul style="list-style-type: none"> ◦ One set of four interconnect brackets for connecting the system cabinets with side panels on ◦ One set of four interconnect brackets for connecting the system cabinets with the side panels off • Four M12x20 Torx-30 screws used in system cabinet with side panels on. • Eight M6x10 countersunk Torx-30 screws used in system cabinet with side panels off.
Support rail kit	<p>If you ordered additional support rails with your system cabinet, each kit contains one left and one right support rail.</p> <p>Attention: The support rails and kit are designed to fit only the NetApp 42U 1280 mm system cabinet. Do not use the rails or a rail kit from other system cabinets because they are not designed for use in the 42U 1280 mm system cabinet.</p> <ul style="list-style-type: none"> • A left and right support rail • Two screws per rail for securing the rail to the system cabinet frame
Crescent wrench	<p>The crescent wrench is used to remove the hold-down brackets on the packing pallet, adjust the system cabinet leveling feet, and install the bolt-down kit brackets, if ordered.</p>

Required tools and equipment

Before unpacking and installing on your system cabinet, you should gather the necessary tools and equipment to move the system cabinet into place and install it or to perform maintenance on it.

- The appropriate hardware guide for your disk shelves
- The appropriate installation and setup instructions for your system
[NetApp All Flash FAS Resources](#)
[NetApp FAS Storage Systems Resources](#)
[NetApp E-Series Systems Documentation Center](#)
- #1 and #2 Phillips screwdrivers
- Torx driver for system cabinet screws
- Leveling tool for leveling the system cabinet

Space requirements and system cabinet dimensions

When unpacking your system cabinet, you must make sure that you have enough room to remove the system cabinet from the packing material. Also make sure that the intended location for the system cabinet is large enough for you to move the cabinet into place.

Required space for unpacking the system cabinet

The following table defines the requires space needed to unpack and install your system cabinet:

Dimensions	U.S.	Metric
Shipping ramp length	80 in.	203.2 cm
Clearance beyond the ramp for cabinet mobility	72 in.	182.9 cm
Shipping pallet depth	59 in.	149.9 cm
Shipping pallet width	42 in.	106.6 cm
Shipping pallet and packaging height	86 in.	218.4 cm
Total rack space, 42U	73.5 in.	186.7 cm
Rail load capacity	Supports all current systems	Supports all current systems
Empty weight	~400 lbs (~181 kg) lbs	~ 181 kg
Fully loaded ship weight	Up to 1,800 lbs	Up to 816.5 kg
Fully loaded static weight	Up to 2,700 lbs	Up to 1,224.7 kg
Front service clearance	47.2 in.	120 cm
Rear service clearance Note: The rear door is split. Actual minimum rear clearance is approximately 1/2 the recommendation.	30 in.	76.3 cm

Dimensions	U.S.	Metric
Minimum side clearance for panel removal	24 in.	61 cm
Minimum top clearance	12 in.	30 cm

System cabinet exterior dimensions

The following illustration shows the front, rear, and side views of the system cabinet:

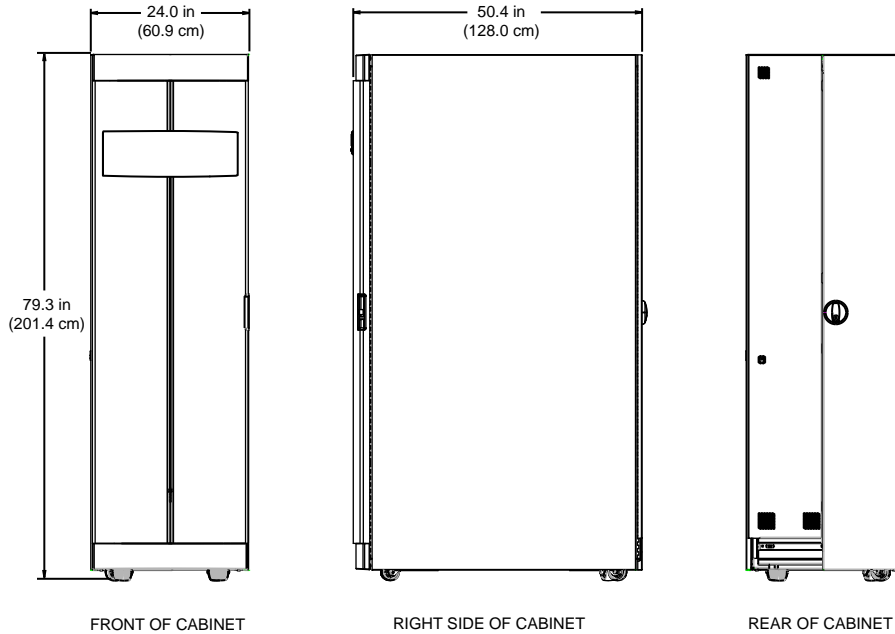

The following illustrations show top and bottom views of the system cabinet, and identify the openings through which you can run cable bundles from the floor of your data center into the system cabinet. The illustrations also show the location of the system cabinet casters and leveling feet.

Caution: To prevent your system cabinet from falling through the data center floor, do not attempt to roll the system cabinet over a floor opening that is wider than the cable access opening at the bottom of the system cabinet.

TOP VIEW OF CABINET

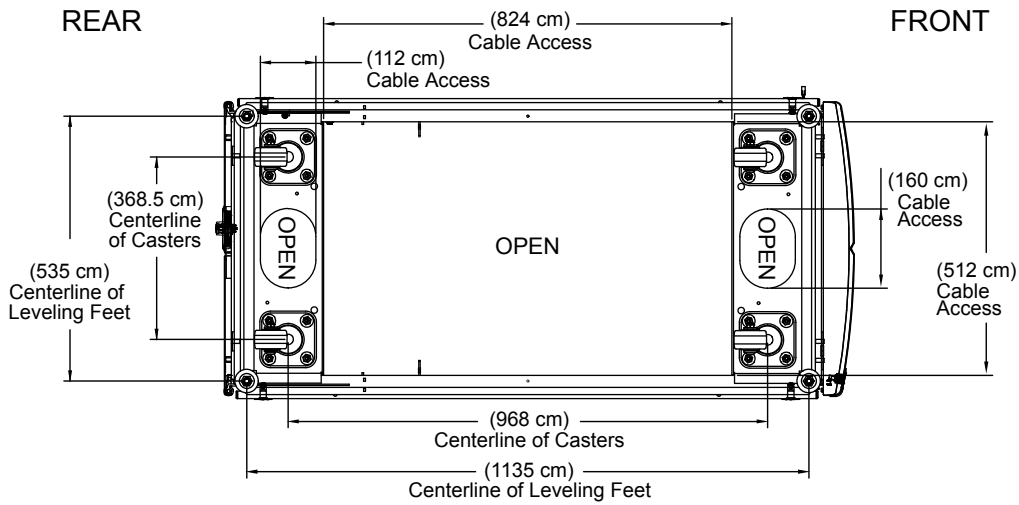
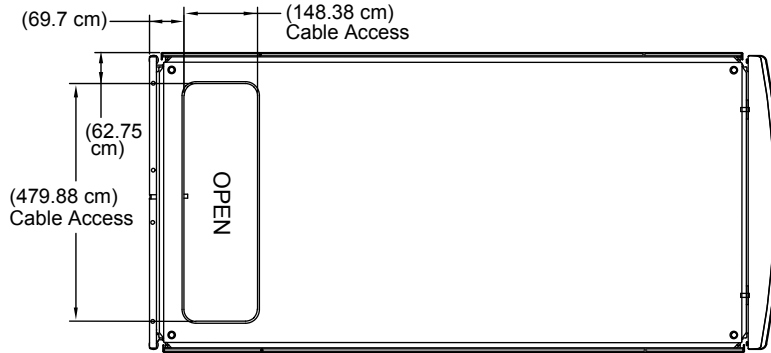

BOTTEM VIEW OF CABINET

Supported PDU types and specifications

The system cabinet supports different Power Distribution Unit (PDU) types. The PDUs are compliant with NEMA or IEC.

The most current information for PDUs supported in your system cabinet is listed in the Hardware Universe.

hwu.netapp.com

Unpacking the system cabinet

You must remove the packing material that surrounds your system cabinet before you move it into place. You should also recycle the packing material after the cabinet is unpacked.

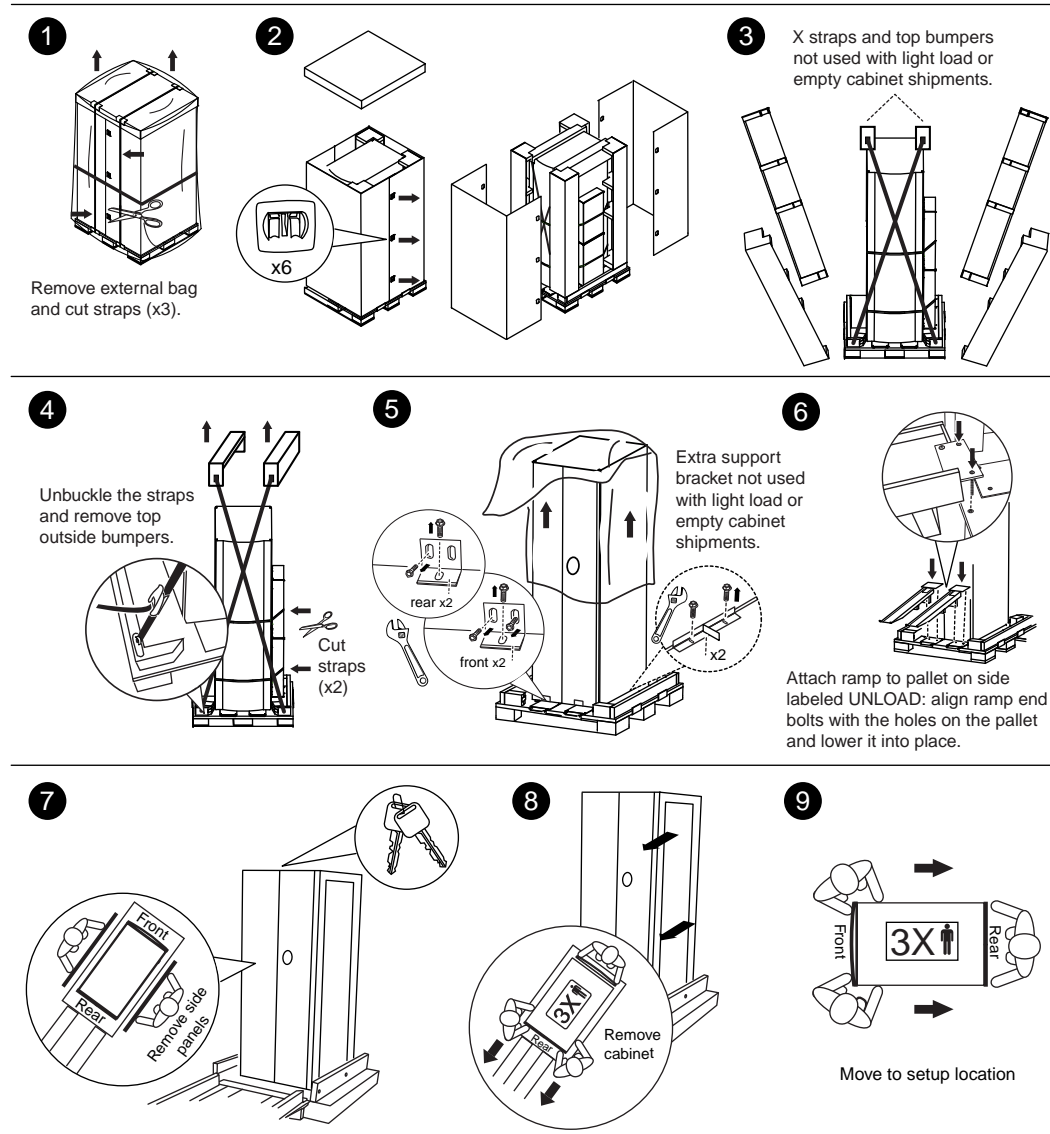

Installing a system cabinet

You can order a system cabinet with NetApp storage controllers and disk shelves installed in it or an empty system cabinet if you already have NetApp equipment. Several system cabinets can be connected together by using the optional interconnect kit, and they can be anchored to the data center floor by using the optional bolt-down kit.

Installing the cabinet interconnect kit

You can connect system cabinets together by using the optional cabinet interconnect kit. It is recommended that you install the kit to prevent the cabinets from pulling apart and damaging system cables.

Steps

1. Place the system cabinets close together.

The cabinets should be arranged similarly to the following illustration, with the cabinet with the controller modules in the middle, and the cabinets with additional disk shelves on either side. The sides of the cabinets should be close, but do not need to touch each other yet.

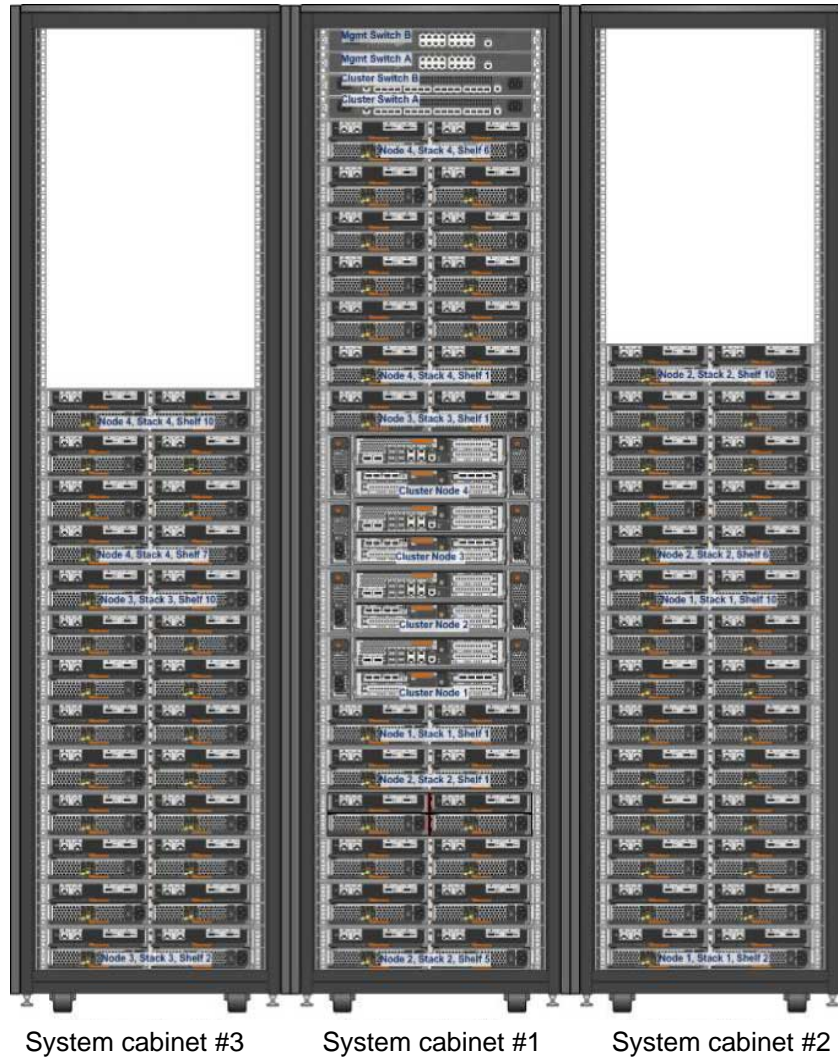

2. If you are installing the interconnect kit with the side panels on as recommended, reinstall the side panels that were removed during unpacking:
 - a. Lift the side panel, tilting it about 15 degrees away from the system cabinet bottom, and then hang it over the lip at the top of the system cabinet frame.
 - b. Gently push the side panel against the cabinet frame, and then lock it in place with the key.
 - c. Repeat these substeps for the remaining side panels.
3. If you are installing the interconnect kit with the side panels removed, remove the front door whose hinges are on the edge where the cabinets meet:
 - a. Unlock and open the front door that is being removed.
 - b. Use the following illustration for reference to unplug the power to the illuminated bezel:

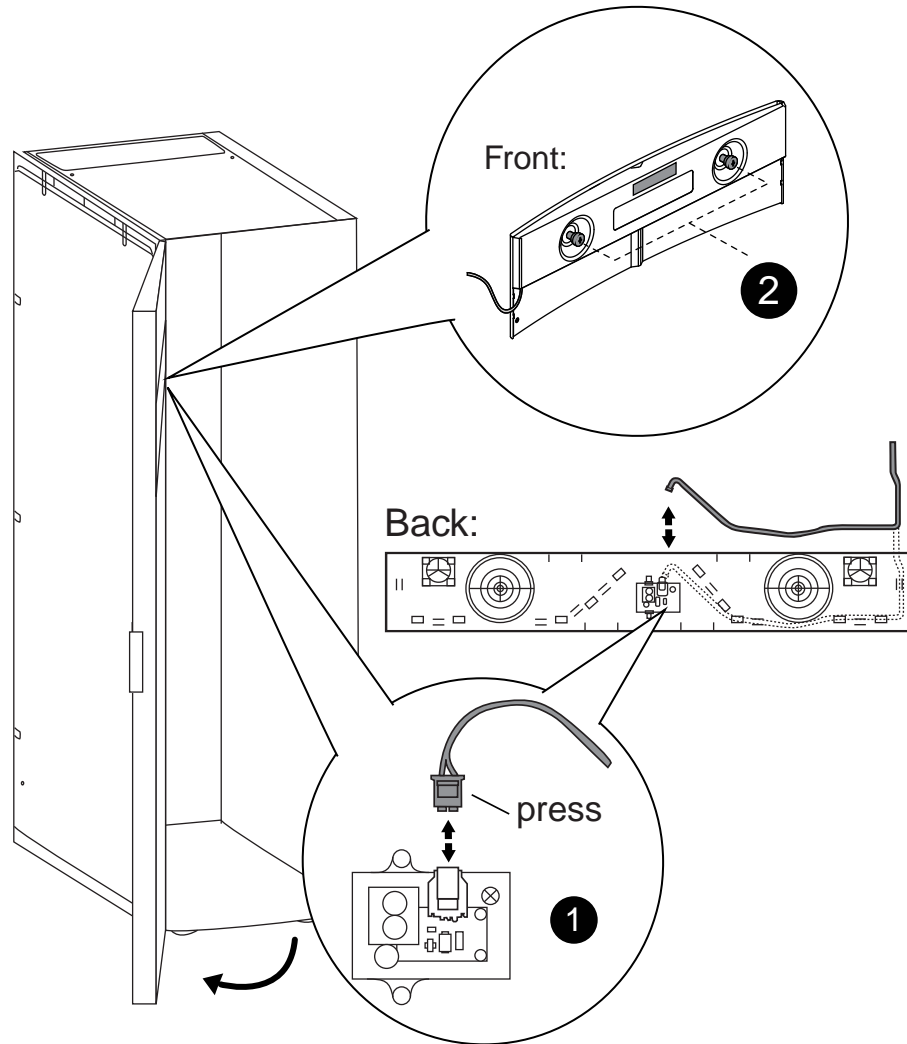

1	Illuminated bezel circuit board and cable
2	Back panel and thumbscrews

c. Use the following illustration for reference to remove the front door:

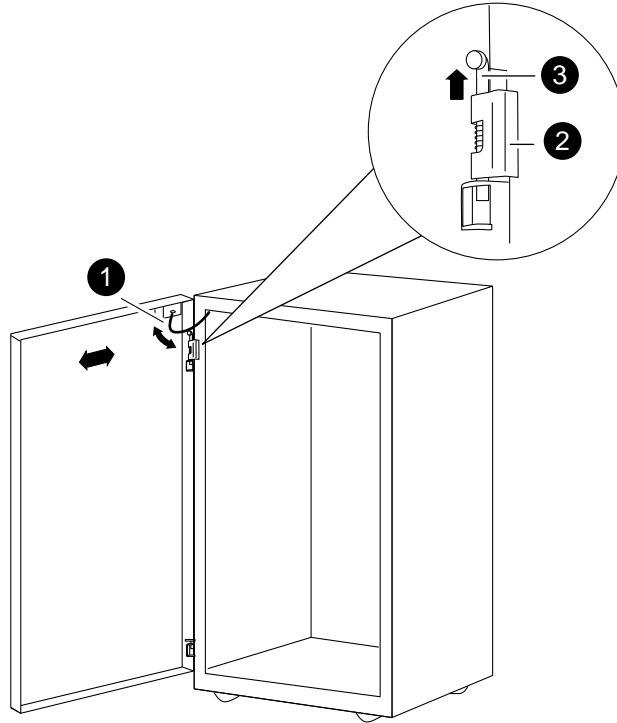

1	Door grounding cable
2	Door top hinge
3	Hinge pin

Make sure that you set the removed doors in a safe place so that they are not accidentally damaged.

4. Remove the rear door whose hinges are on the edge where the cabinets meet:
 - a. Unlock and open the rear door that you are removing.
 - b. Lift the top hinge pin until it clears the bottom of the hinge.
 - c. Gently tip the top of the door away from the system cabinet frame, and then release the hinge pin.
 - d. Lift the door off the bottom hinge, and then set the door aside.
5. Move the system cabinets completely together, and then align and level them by adjusting the four leveling feet at the bottom of the system cabinets.
6. Install the interconnect brackets.
 - Use the following illustration for reference if you are installing the interconnect brackets with the system cabinet side panels on, as recommended:

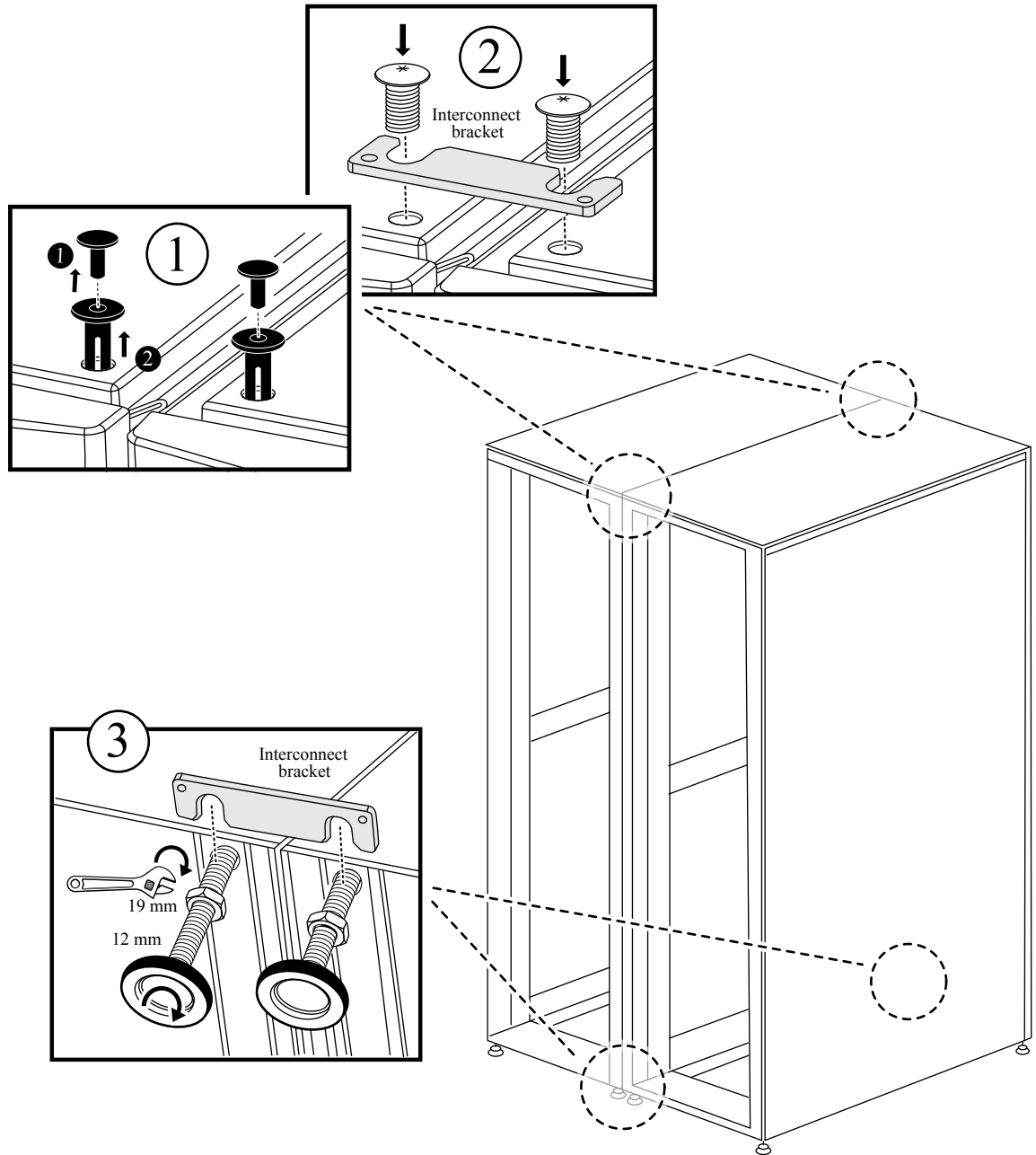

1	Plastic push-in rivets on the system cabinet top
2	Top interconnect bracket
3	Bottom interconnect bracket

- Use the following illustration for reference if you are installing the interconnect brackets with the system cabinet side panels off:

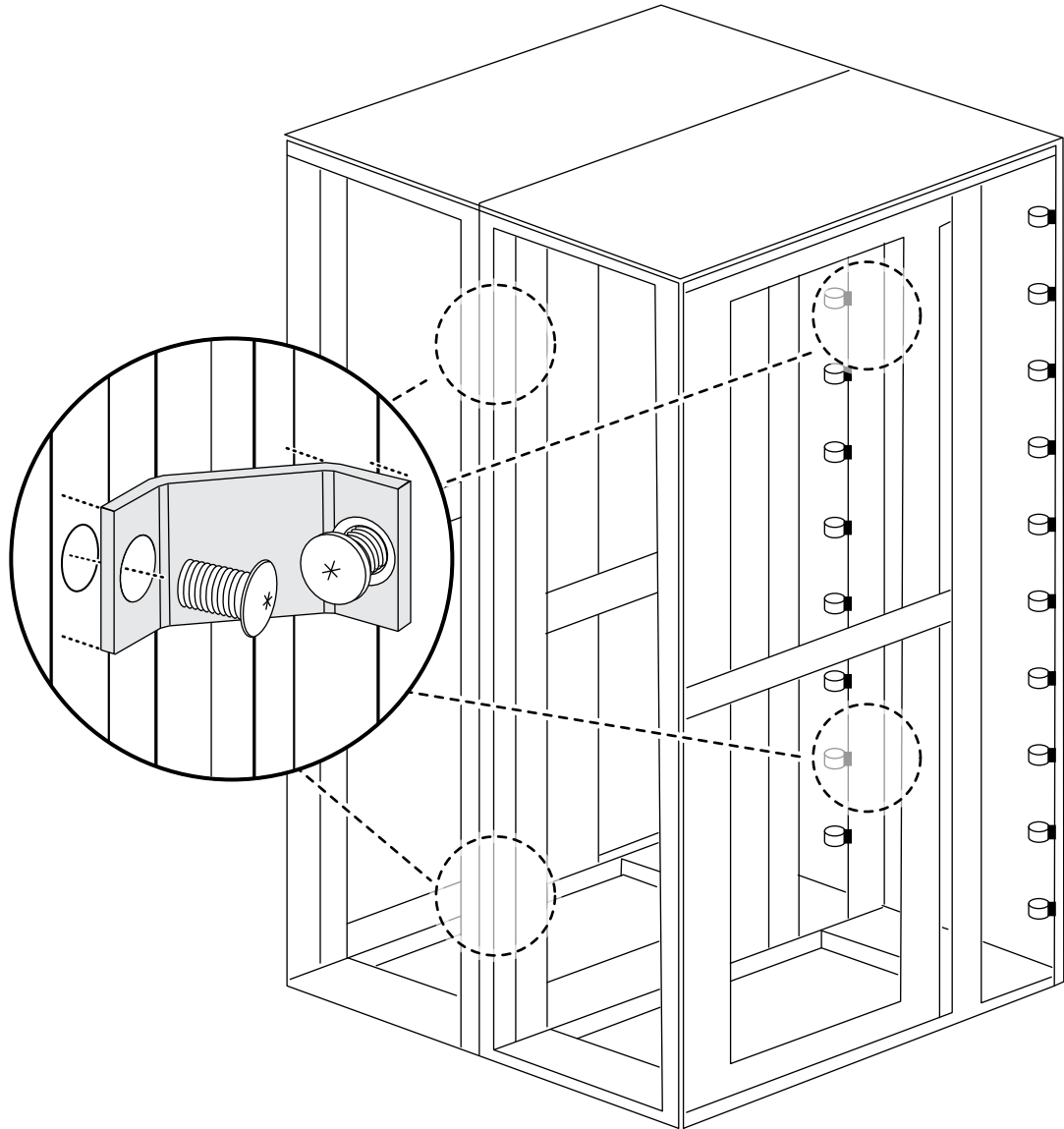

7. Repeat the process for any remaining system cabinets.
8. Tighten all interconnect bracket screws.

Installing the bolt-down kit

You can secure the system cabinet to the floor by installing the optional bolt-down kit. Installing the kit prevents the system cabinets from being rolled out of position.

Before you begin

You must supply the appropriate anchor bolt for your floor for each bolt-down bracket.

Steps

1. Mark the area on your floor where the system cabinet will be installed, and then roll the cabinet into place.

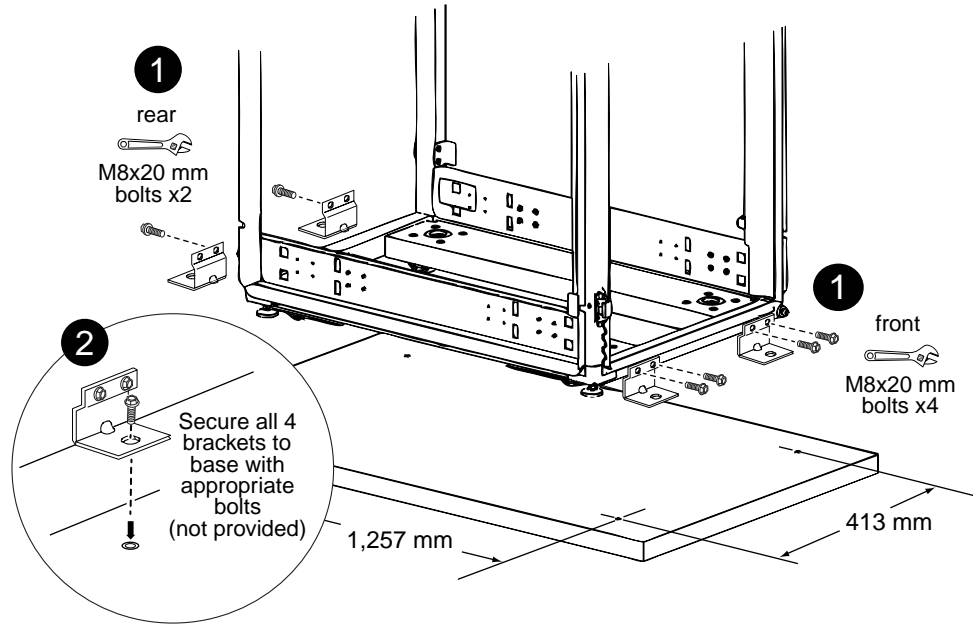

1	Front and rear bolt-down brackets
2	Location of floor anchor point on the bracket

2. Mark the anchoring points where the rear bolt-down brackets will be anchored to the floor, and then drill the holes for the brackets.
Be sure to use the appropriate bolt sizes and type for your floor.
3. If the bolt-down brackets are too low to align with the mount points on the system cabinet frame, place a spacer bracket over the hole in the floor.
4. Loosely bolt the rear brackets to the floor, and then using the kit bolts, bolt the brackets to the cabinet frame.
5. Mark the anchoring points where the front bolt-down brackets will be anchored to the floor, and then drill the holes for the brackets.
6. If the bolt-down brackets are too low to align with the mount points on the system cabinet frame, place a spacer bracket over the hole in the floor.
7. Bolt the front brackets to the floor, and then using the kit bolts, bolt the brackets to the cabinet frame.
8. Lower the leveling feet as needed, and then tighten the rear bolt-down brackets to the floor.

Installing additional support rails

Your system cabinet has some support rails already installed in it. If you need additional support rails for your system, you must install them before installing your system components.

About this task

This task applies to all controller and disk shelves except the DS212C and the DE212C disk shelves. Use the instructions in the rail kit flyer applicable to those two disk shelves.

[Installing a DE212C or DS212C Shelf in a Two-Post or Four-Post Rack](#)

Steps

1. Determine how much space your equipment requires.

Calculate the amount of U space (1.75 inches per U) the equipment requires, based on the equipment height, and then determine where the equipment will be installed in the system cabinet based on available space.

2. Locate where you need to install the support rails, and then install them using the following illustration for reference:

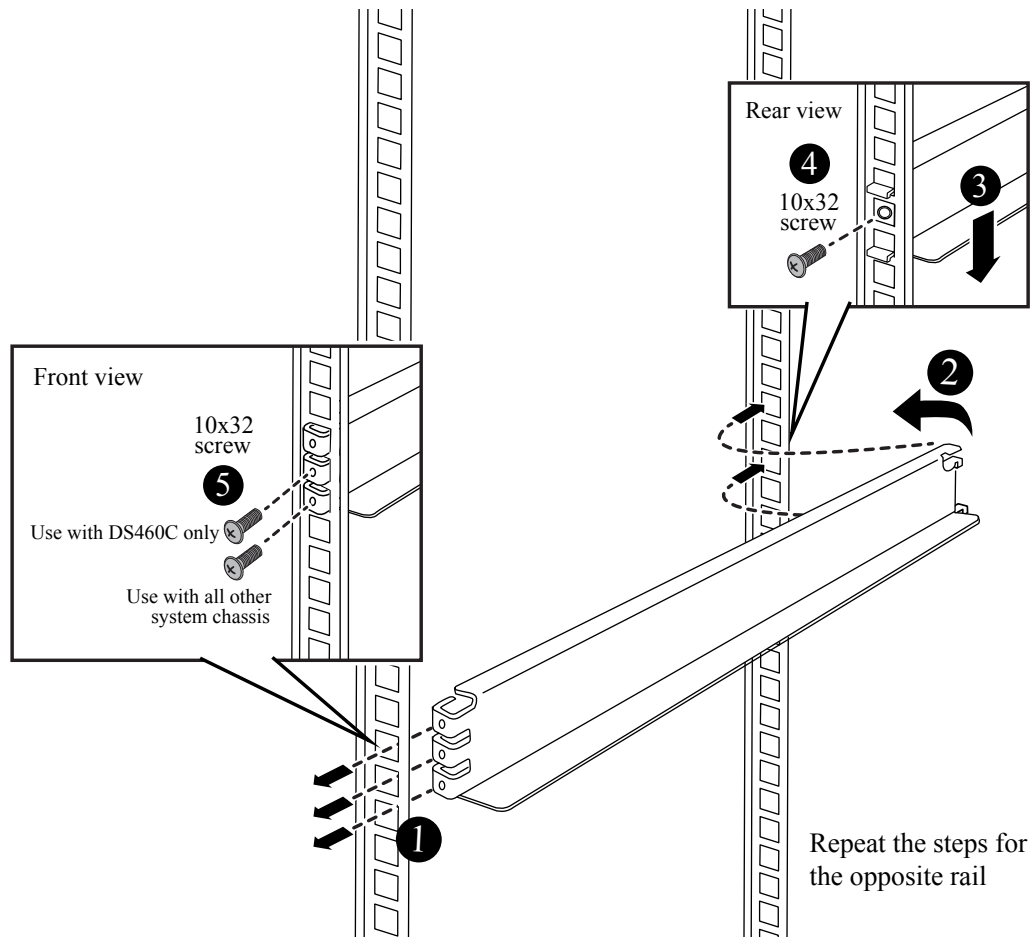

3. If your equipment mounting flanges extend beyond the screw holes in the support rail, install cage nuts above the support rail, where needed.

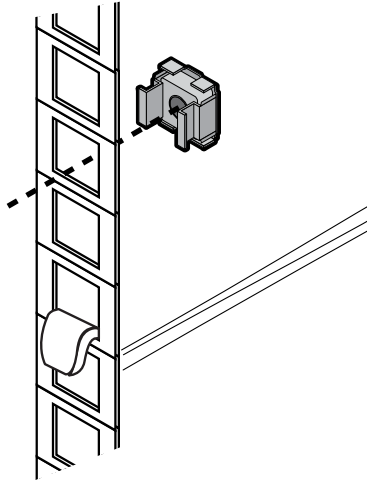

Installing equipment in the system cabinet

After you have installed any additional support rails into the system cabinet, you can add more system components to your prepopulated system cabinet or add your existing system components to an empty system cabinet.

Steps

1. Unlock and open the rear doors of the system cabinet and the front door, if it is not already open.
2. Install your equipment into the system cabinet as described in the installation instructions accompanying your equipment.

The storage controllers should be in the middle of the system cabinet. The disk shelves should be above and below the storage controllers. Any switches should be at the very top of the system cabinet.

Note: If your equipment mounting flanges extend beyond the screw holes in the support rail, install cage nuts above the support rail where needed to secure the equipment to the cabinet upright.

3. Install blanking panels over any empty bays in the system cabinet.

If you receive the system cabinet with equipment already installed, you must remove the tie-down rails on top of the equipment that is directly below empty cabinet bays, as shown in the following illustration:

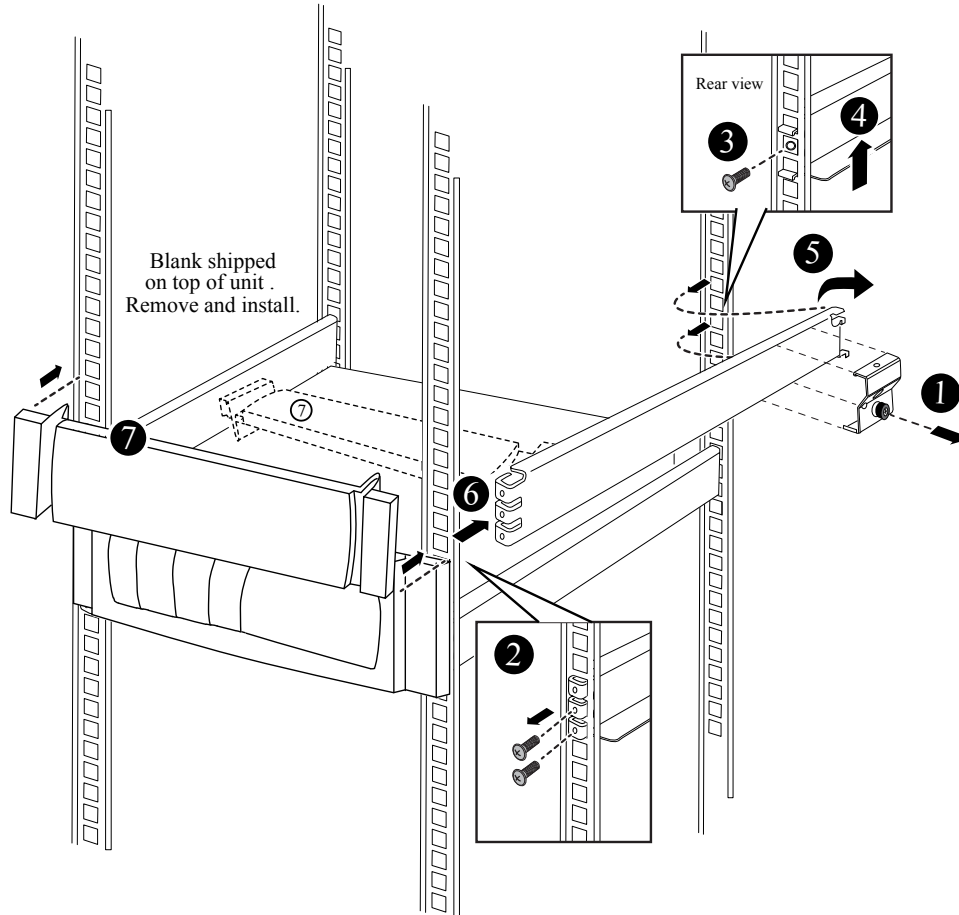

4. Reinstall the front and rear system cabinet doors.

Powering on the system cabinet

You must connect the system components to the PDUs, route the PDU cables to the AC power sources, connect them to the power sources, and power on the system.

Before you begin

You must have separate power circuits available for each PDU in your system cabinet.

Steps

1. Connect your equipment to the PDUs, making sure that you connect each component's power supplies to a PDU on opposite sides of the system cabinet.
2. Feed the PDU power cables through an opening in the system cabinet.
Use one of the following openings:
 - The top of the system cabinet
 - Between the rear door bottom and frame of the system cabinet
 - Through the floor opening and under the system cabinet
3. Turn off the power switches or circuit breakers on the PDUs.

4. Plug each PDU power cable into individual AC power sources that are on separate AC circuits.
5. Turn on the power switches or circuit breakers to the PDUs.
6. Turn on the power to your components, and then boot the system.
7. Close and lock the system cabinet doors.

Replacing PDUs

You can replace a failed PDU in your system cabinet or replace an existing PDU with a different type of PDU.

Before you begin

The replacement PDU must be supported by your system cabinet and must provide sufficient power to the installed equipment.

hwu.netapp.com

Steps

1. Turn off the circuit breakers on the target PDU, and then unplug the old PDU from the AC power source.
2. Ground yourself to the system cabinet, and then unplug the power cords from each of the system components and from the PDU.
3. Remove the screws from the PDU frame, bottom screw first.
Note: Ensure that you support the PDU with one hand while you remove the last screw from the top of the PDU. This prevents the PDU from dropping or falling toward you after the screw is removed.
4. Remove the old PDU from the system cabinet.
Make sure that you keep track of the mounting screws so that you can reuse them when installing the replacement PDU.
5. Remove the brackets from the old PDU, and then install them on the back of the replacement PDU.
6. While supporting the replacement PDU, align the slot on the mounting bracket of the PDU with the top holes of the frame on the inside of the system cabinet, and then secure the PDU to the system cabinet frame using the mounting screws from the old PDU.
7. Secure the bottom of the PDU to the system cabinet frame, and then tighten all of the mounting screws.
8. Verify that all of the power switches or circuit breakers are in the Off position.
If the circuit breakers are not in the Off position, push a small screwdriver or straightened paper clip into the slot to the right of the Off label to trip the circuit breaker and turn off the circuit.
9. Plug the system power cords into the PDU, plugging each component into the PDU outlet directly across from the component.
Tip: A best practice is to distribute the total load across the PDU branches, making each branch load as equal as possible.
10. Lock each component power cable plug in place with the cable retainer clip above it by sliding the curved edge of the cable retainer clip over the plug shoulder.
11. Plug the PDU power cord into the AC power source.
12. Turn on the PDU power switches or PDU circuit breakers.
For PDU circuit breakers, the button is on when it is flush with the PDU frame.

Reversing the system cabinet front door

You can change the direction the front door opens by removing the illuminated badge, door, top hinge, and related hardware, and then installing them on the opposite side of the front of the system cabinet frame.

Before you begin

About this task

You need the following tools and equipment to complete the door reversal for system cabinets with illuminated badges:

- A Phillips screwdriver
- A 5-mm Allen wrench; magnetic Allen wrench is recommended
- Needle-nose pliers
- A step ladder so that you can easily access the Allen bolts in the top hinge

Removing the illuminated badge

Removing the illuminated badge requires that you open the system cabinet front door, unplug the power cord from the back of the badge, and then remove the badge components from the system cabinet door.

About this task

Use the following illustration along with the following steps:

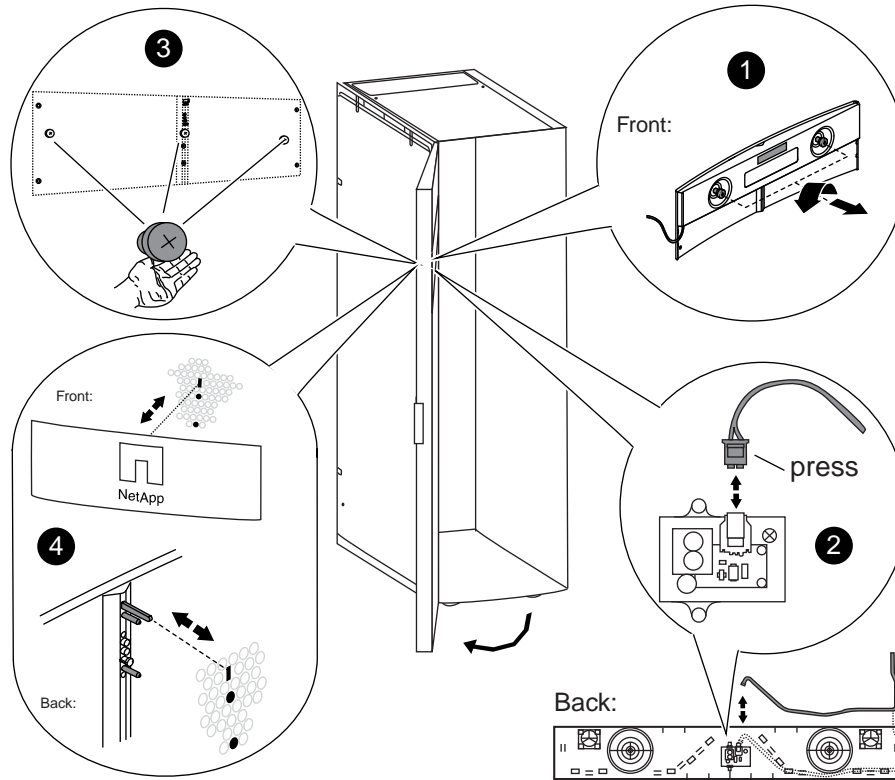

Steps

1. Unlock and open the system cabinet front door.
2. Loosen the captive screws on the badge back panel on the inside of the door, and then gently pull the back panel away from the door mesh.
3. Unplug the power cord from the back panel by pressing the locking clip on the plug, unplugging the cord from the socket, and removing the cable from the back panel.

Set the back panel aside.

4. Carefully remove the screws from the back of the badge.

Note: The stems on the thumbscrews are very short. Place your free hand under the screw to catch the thumbscrew if you drop it.

5. Remove the badge from the front of the door and set it aside.

Removing the system cabinet door

You must remove the system cabinet door and side panels to move the illuminated badge and components, and to reverse the door.

Steps

1. Open the system cabinet door if it is not already open.
2. Perform the appropriate action depending on whether your cabinets are connected with the interconnect kit.

If your system cabinet is...	Then...
Not connected to another system cabinet	Go to the next step.
Connected to another system cabinet with an interconnect kit	Remove all four interconnect kit brackets and set the brackets and screws in a safe place.

3. Unlock both side panels, disconnect the grounding wires from the side panels, and then remove them and set them aside.
4. Disconnect the grounding wire from the grounding spade located at the top of the door.
5. Unscrew the grounding lug and wire assembly from the system cabinet frame and set it aside.
6. Unscrew the grounding lug assembly from the system cabinet door and set it aside.
7. Lift the top hinge pin until it clears the bottom of the hinge.
8. Gently tip the top of the door away from the system cabinet frame, and then release the hinge pin.
9. Lift the door off the bottom hinge, and set the door aside.

Moving the badge power supply and cabling

You must move the power supply and illuminated badge cabling to the opposite side of the system cabinet frame before you reverse the door and reinstall the illuminated badge.

Before you begin

You must have removed the system cabinet door and side panels.

About this task

You must move the illuminated badge power supply, power cable, and cabling conduit to the opposite side of the system cabinet when you reverse the system cabinet door. The assembly is designed so that the cable to the badge is on the side of the cabinet where the door hinge is installed.

Steps

1. Open the power cable retaining clip, and then disconnect the power cable from the power supply.
2. Remove the power supply housing and power supply, using the illustration for reference:

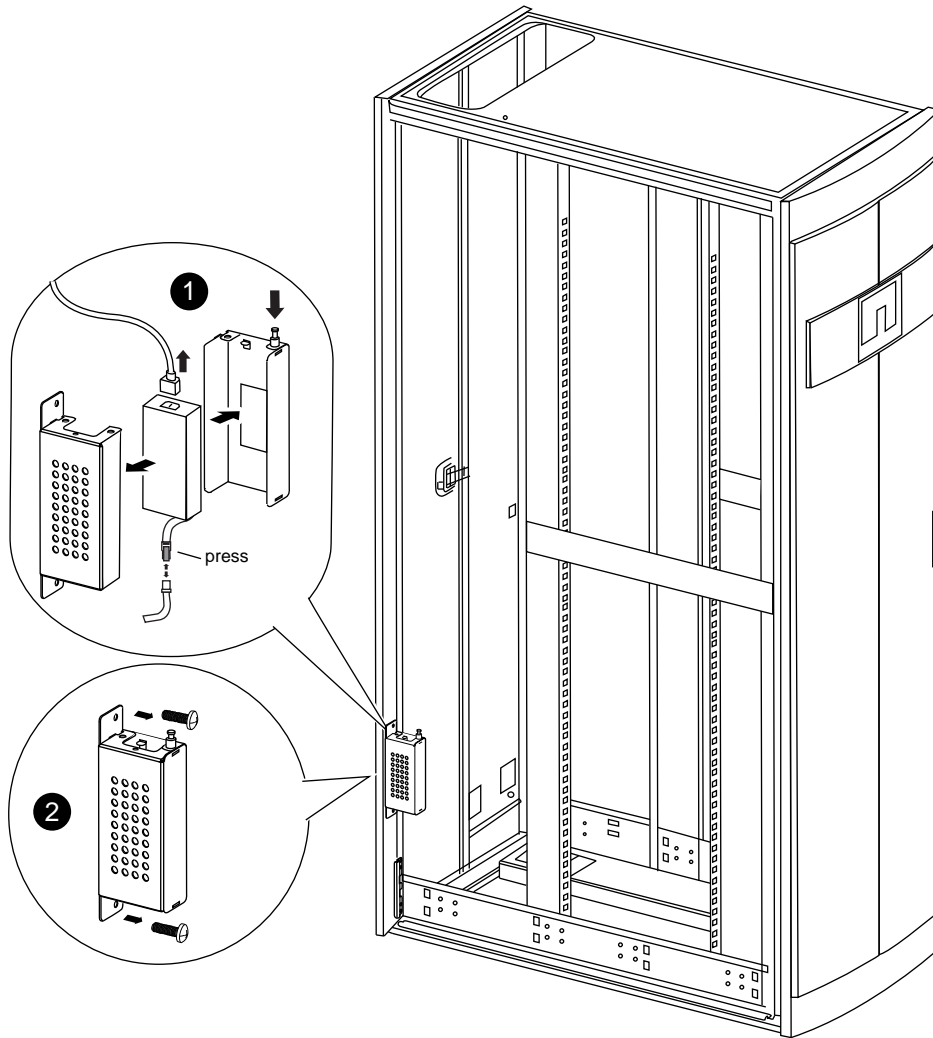

- a. Lift the retaining pin on the power supply housing, and then remove the housing cover by rotating it downward and lifting it off the rear power supply housing.

Note: The power supply is attached to the power supply housing with a hook and loop patch.
 - b. Disconnect the power supply from the illuminated badge cable, and then set the power supply and power supply cover to the side.
 - c. Remove the screws from the top and bottom of the power supply housing that is attached to the system cabinet frame, and then remove the power supply housing.
3. Install the power supply and power supply housing on the opposite side of the system cabinet:
- a. Locate the two screw holes next to each other on the cabinet frame, and then attach the top of the power supply housing to the bottom-most of the two screw holes.

Note: You might need to remove the bottom cable retention strap, if present.
 - b. Secure the bottom of the power supply housing to the system cabinet frame.
 - c. Install the power supply cover and power supply by aligning the cover hooks with the power supply back, pulling the plunger up on the cover, rotating the plunger closed, and then releasing the plunger.

4. Remove the bezel power supply conduit by removing the conduit retaining clips from the retaining clips, and then slide the conduit off the power cable.

Keep the retaining clips and screws for installing the conduit on the opposite side of the cabinet.

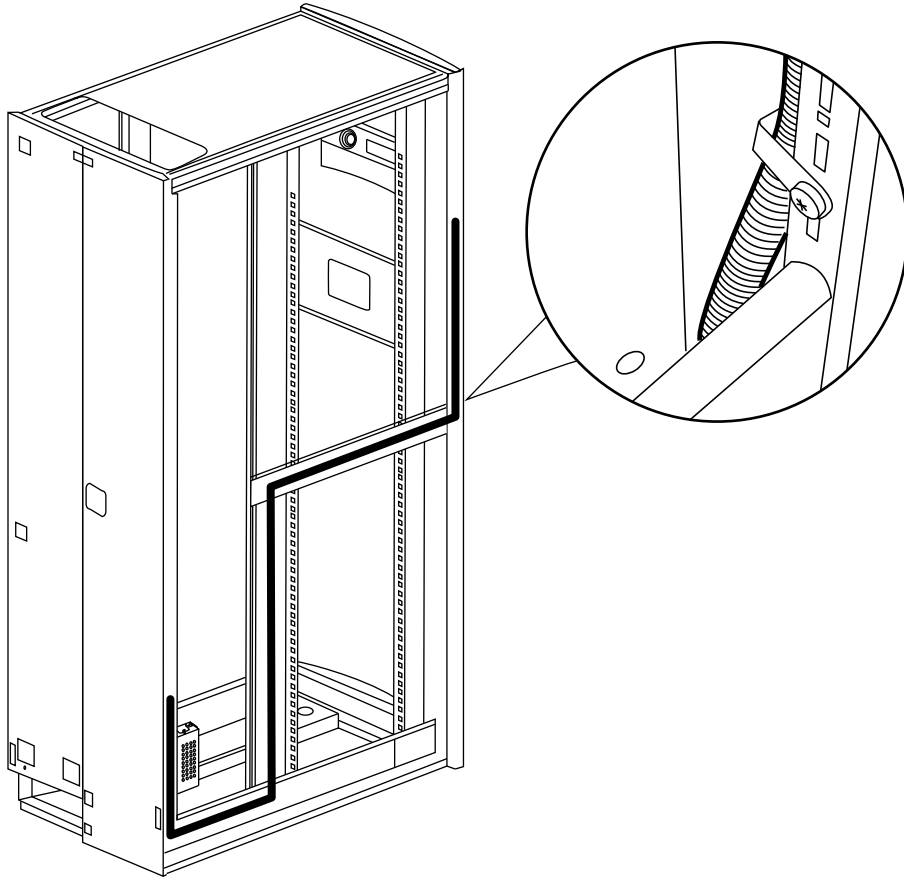

5. Move the badge power cable to the other side of the cabinet:

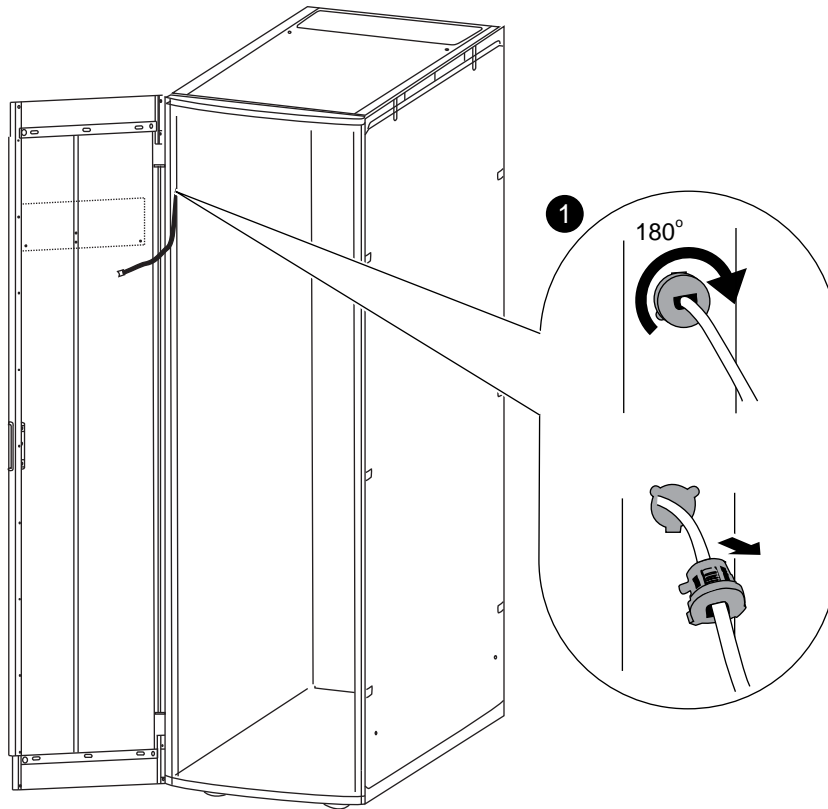

- a. Rotate the rubber cable retainer on the cabinet upright 180° to the right, remove it from the system cabinet frame, and then gently pull the cable out of the system cabinet.
 - b. Move the cable to the other side of the cabinet, and then thread it completely through the hole near the top of the cabinet upright.
 - c. Align the rubber cable retainer with the hole in the frame, push it in as far as it will go, and then rotate the cable retainer 180° to the left to secure it.
 - d. Run the cable along the cabinet frame to the back of the cabinet.
- 6.** Reinstall the cable conduit:
- a. Slide the conduit over the PDU power cable and route the conduit along the system cabinet frame to the PDU.
 - b. Install the conduit retaining clips from the other side of the cabinet over the conduit to secure it to the cabinet frame.
- 7.** Plug the badge cable back into the power supply, but do not reconnect the power supply to the power source.

Reversing the door hinge and lock catch

When reversing the system cabinet door, you must move the system cabinet door hinge and lock catch to the opposite front-side system cabinet upright.

Before you begin

You need the following tools:

- Phillips screwdriver

- 5 mm Allen wrench; magnetic Allen wrench is recommended
- Needle-nose pliers
- Step ladder so that you can easily access the Allen screws in the top hinge

Steps

1. Remove the screws securing the top hinge from the system cabinet frame, and set the screws and hinge aside.

Attention: Be careful when removing the Allen screws to avoid dropping them into the cabinet frame. Spare Allen screws are provided in the spares kit that shipped with your system cabinet.
2. Remove the screws securing the bottom hinge from the system cabinet frame, and set the screws and hinge aside.

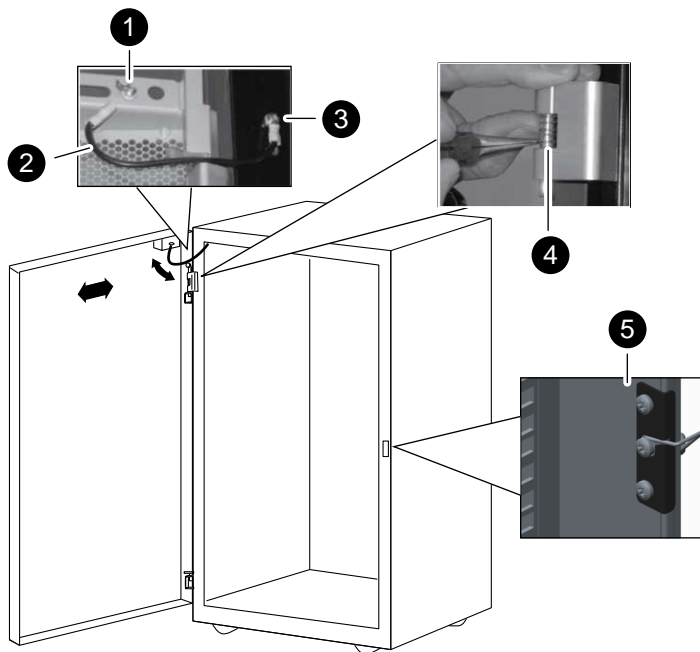

1	Door grounding screw with grounding wire spade
2	Grounding wire
3	Frame grounding wire lug
4	Top front door hinge with hinge pin held by retaining clip
5	Lock catch

3. Reverse the hinge pin from the top hinge:
 - a. Lift the hinge pin and expose the retaining clip on the hinge pin shaft.

- b. Using the needle-nose pliers, gently remove the retaining clip from the hinge pin shaft and set it aside.
 - c. Slide the hinge pin and spring out of the hinge body.
 - d. Rotate the hinge so that the thread holes are facing the opposite side of the hinge, and then install the hinge pin and spring back into the hinge.
 - e. Install the hinge retaining clip onto the hinge pin.
Make sure that you push the retaining clip completely onto the hinge pin.
4. Reinstall the hinges:
 - a. Insert the top Allen screw through the system cabinet upright, aligning it with the top threaded hole on the top hinge, and then partially tighten the Allen screw.
Do not completely tighten the screw until after the second Allen screw is installed.
 - b. Insert the bottom Allen screw through the system cabinet upright, aligning it with the bottom threaded hole on the top hinge, and then partially tighten the Allen screw.
 - c. Tighten the top and bottom Allen screws.
 - d. Repeat these steps for the bottom hinge.
 5. Remove the screws from the lock catch, and then move the lock catch to the opposite front-side system cabinet upright.
 6. Rotate the catch 180 degrees, and then secure it to the system cabinet upright.

Reinstalling the door and illuminated badge

After you move the power supply and components to the other side of the system cabinet and moved the hinges and lock catch, you must reinstall the system cabinet door and the illuminated badge, and then reconnect the badge to the power source.

Reinstalling the system cabinet door

After you reverse the door hinge and door catch, you must reinstall the grounding wire and lug assembly and wire, and the system cabinet front door prior to reinstalling the illuminated badge.

Steps

1. Rotate the door 180 degrees.
2. Align the bottom of the door with the bottom hinge post, and then seat the door bottom on the hinge post.
3. Lift the top hinge pin so that it clears the hinge housing.
4. Tip the top of the door into the hinge housing so that the hinge pin and door hinge are aligned, and then release the hinge pin.
Make sure that the hinge pin is seated completely through the door hinge and the bottom of the door hinge housing.
5. Reattach the grounding lug and wire assembly to the system cabinet frame on the same side of the newly reversed front door and reinstall the grounding lug with spade on the top of the system cabinet door.
6. Reattach the grounding wire to the spade on the grounding lug assembly on the system cabinet door.

7. Reinstall either the side panels or the interconnect brackets, as applicable:
 - If your system cabinet is not connected to another system cabinet, reinstall the side panels.
 - If your system cabinet is connected to another system cabinet with an interconnect kit, reinstall the interconnect brackets.

Reinstalling the illuminated badge

After the system cabinet door is installed, you need to install the illuminated badge to complete the door reversal process, and then close and lock the front door.

Steps

1. Using the following illustration for reference, reinstall the illuminated badge on the front door of the system cabinet:

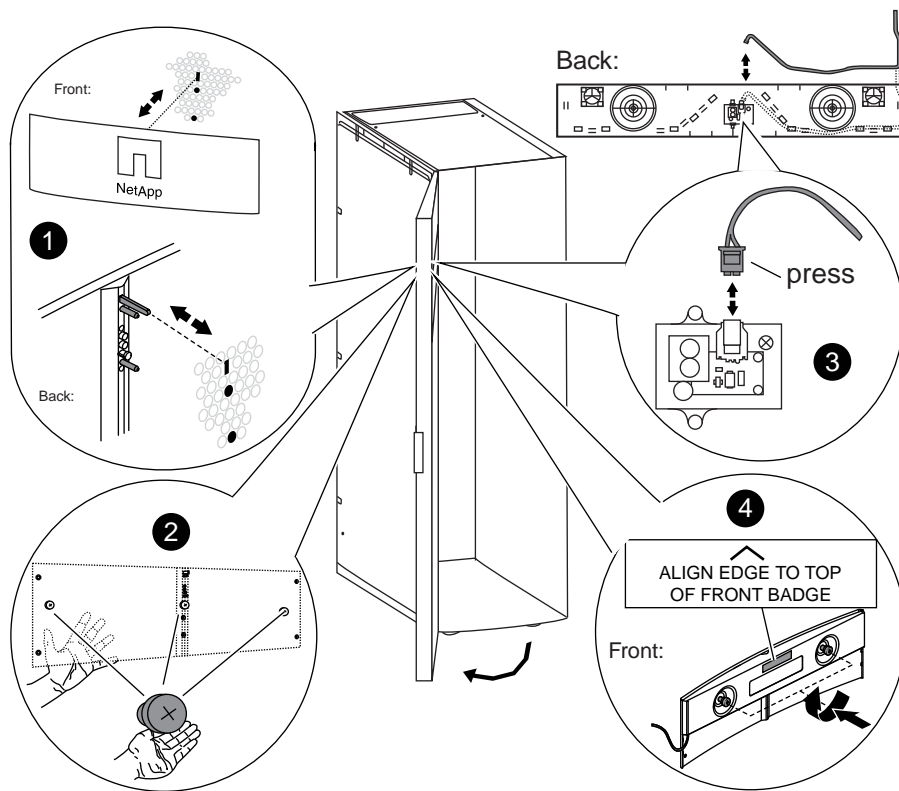

2. Close and lock the front door.

Copyright information

Copyright © 2018 NetApp, Inc. All rights reserved. Printed in the U.S.

No part of this document covered by copyright may be reproduced in any form or by any means—graphic, electronic, or mechanical, including photocopying, recording, taping, or storage in an electronic retrieval system—without prior written permission of the copyright owner.

Software derived from copyrighted NetApp material is subject to the following license and disclaimer:

THIS SOFTWARE IS PROVIDED BY NETAPP "AS IS" AND WITHOUT ANY EXPRESS OR IMPLIED WARRANTIES, INCLUDING, BUT NOT LIMITED TO, THE IMPLIED WARRANTIES OF MERCHANTABILITY AND FITNESS FOR A PARTICULAR PURPOSE, WHICH ARE HEREBY DISCLAIMED. IN NO EVENT SHALL NETAPP BE LIABLE FOR ANY DIRECT, INDIRECT, INCIDENTAL, SPECIAL, EXEMPLARY, OR CONSEQUENTIAL DAMAGES (INCLUDING, BUT NOT LIMITED TO, PROCUREMENT OF SUBSTITUTE GOODS OR SERVICES; LOSS OF USE, DATA, OR PROFITS; OR BUSINESS INTERRUPTION) HOWEVER CAUSED AND ON ANY THEORY OF LIABILITY, WHETHER IN CONTRACT, STRICT LIABILITY, OR TORT (INCLUDING NEGLIGENCE OR OTHERWISE) ARISING IN ANY WAY OUT OF THE USE OF THIS SOFTWARE, EVEN IF ADVISED OF THE POSSIBILITY OF SUCH DAMAGE.

NetApp reserves the right to change any products described herein at any time, and without notice. NetApp assumes no responsibility or liability arising from the use of products described herein, except as expressly agreed to in writing by NetApp. The use or purchase of this product does not convey a license under any patent rights, trademark rights, or any other intellectual property rights of NetApp.

The product described in this manual may be protected by one or more U.S. patents, foreign patents, or pending applications.

Data contained herein pertains to a commercial item (as defined in FAR 2.101) and is proprietary to NetApp, Inc. The U.S. Government has a non-exclusive, non-transferrable, non-sublicensable, worldwide, limited irrevocable license to use the Data only in connection with and in support of the U.S. Government contract under which the Data was delivered. Except as provided herein, the Data may not be used, disclosed, reproduced, modified, performed, or displayed without the prior written approval of NetApp, Inc. United States Government license rights for the Department of Defense are limited to those rights identified in DFARS clause 252.227-7015(b).

Trademark information

NETAPP, the NETAPP logo, and the marks listed on the NetApp Trademarks page are trademarks of NetApp, Inc. Other company and product names may be trademarks of their respective owners.

<http://www.netapp.com/us/legal/netapptmlist.aspx>

How to send comments about documentation and receive update notifications

You can help us to improve the quality of our documentation by sending us your feedback. You can receive automatic notification when production-level (GA/FCS) documentation is initially released or important changes are made to existing production-level documents.

If you have suggestions for improving this document, send us your comments by email.

[*doccomments@netapp.com*](mailto:doccomments@netapp.com)

To help us direct your comments to the correct division, include in the subject line the product name, version, and operating system.

If you want to be notified automatically when production-level documentation is released or important changes are made to existing production-level documents, follow Twitter account @NetAppDoc.

You can also contact us in the following ways:

- NetApp, Inc., 1395 Crossman Ave., Sunnyvale, CA 94089 U.S.
- Telephone: +1 (408) 822-6000
- Fax: +1 (408) 822-4501
- Support telephone: +1 (888) 463-8277

Index

A

adding system components
to prepopulated system cabinets [18](#)

B

bolt-down kits
securing system cabinet to the floor [15](#)

C

cabinets
features for setting up and cabling [4](#)
reversing door hinge and lock catch on system [27](#)
comments
how to send feedback about documentation [33](#)
components
system cabinet setup and cabling [4](#)

D

dimensions
system cabinet [6](#)
documentation
how to receive automatic notification of changes to [33](#)
how to send feedback about [33](#)
doors
reversing system cabinet [27](#)

E

empty system cabinets
installing system components [18](#)
equipment
required for installing [6](#)

F

features
system cabinet setup and cabling [4](#)
feedback
how to send comments about documentation [33](#)
front doors
reversing [22](#)

H

hinges
reversing system cabinet door [27](#)

I

illuminated badge
installing [29](#)
removing [23](#)

illuminated badge removal [23](#)
information
how to send feedback about improving
documentation [33](#)
installation
required tools for [6](#)
installing
additional support rails [16](#)
equipment in an empty system cabinet [18](#)
illuminated badge [29](#)
introduction to [10](#)
interconnect kits
connecting system cabinets together using [10](#)

K

kits
features [4](#)

L

lock catch
reversing system cabinet door [27](#)

M

moving
system cabinet power supply illuminated badge
power supply and cables [24](#)

O

optional kits
description of system cabinet [4](#)

P

PDU internal wiring
supported types of [8](#)
PDUs
replacing [21](#)
supported types of [8](#)
power supplies
moving system cabinet illuminated badge [24](#)
powering on
system cabinets [19](#)

R

reinstalling
the system cabinet door [29](#)
removing
system cabinet door [24](#)
the illuminated badge [23](#)
replacing
PDUs [21](#)
reversing

- system cabinet door hinge and lock catch [27](#)
- the door [22](#)

S

- setup
 - introduction to installing [10](#)
- space requirements
 - system cabinet [6](#)
- suggestions
 - how to send feedback about documentation [33](#)
- support rails
 - installing additional [16](#)
- supported PDUs
 - types of [8](#)
- system cabinet door
 - removing [24](#)
- system cabinet doors
 - reinstalling [29](#)
- system cabinets
 - connecting with the interconnect kit [10](#)
 - dimensions and space requirements [6](#)

- features for setting up and cabling [4](#)
- installing bolt-down kit to secure [15](#)
- introduction to preparing to install [4](#)
- powering on [19](#)
- reversing door hinge and lock catch [27](#)
- unpacking [9](#)

- system components
 - adding to prepopulated system cabinets [18](#)

T

- tools
 - required for installing [6](#)
- Twitter
 - how to receive automatic notification of documentation changes [33](#)

U

- unpacking
 - system cabinets [9](#)