Swapping out a power supply

To replace a power supply in the system, you must perform a specific sequence of tasks.

Before you begin

All other components in the system must be functioning properly; if not, you must contact technical support.

About this task

- The power supplies are redundant and hot-swappable.
To prevent system downtime, you must replace only one power supply at a time.

Note: Power supplies are auto-ranging.

Steps

1. [Removing a power supply](#) on page 1
2. [Installing a power supply](#) on page 3
3. [Completing the replacement process](#) on page 3

Removing a power supply

To remove a power supply, you must identify the one you want to remove, disconnect the power cord, and remove the power supply from the chassis.

About this task

Attention: You should replace the power supply within two minutes of removing it from the chassis. The system continues to function, but Data ONTAP sends messages to the console about the degraded power supply until the power supply is replaced.

Steps

1. Identify the power supply you want to replace, based on console error messages or through the LEDs on the power supplies.
[NetApp Hardware Universe](#)
2. If you are not already grounded, properly ground yourself.
3. Turn off the target power supply and remove the power cord by completing the following substeps, using the illustration for reference:

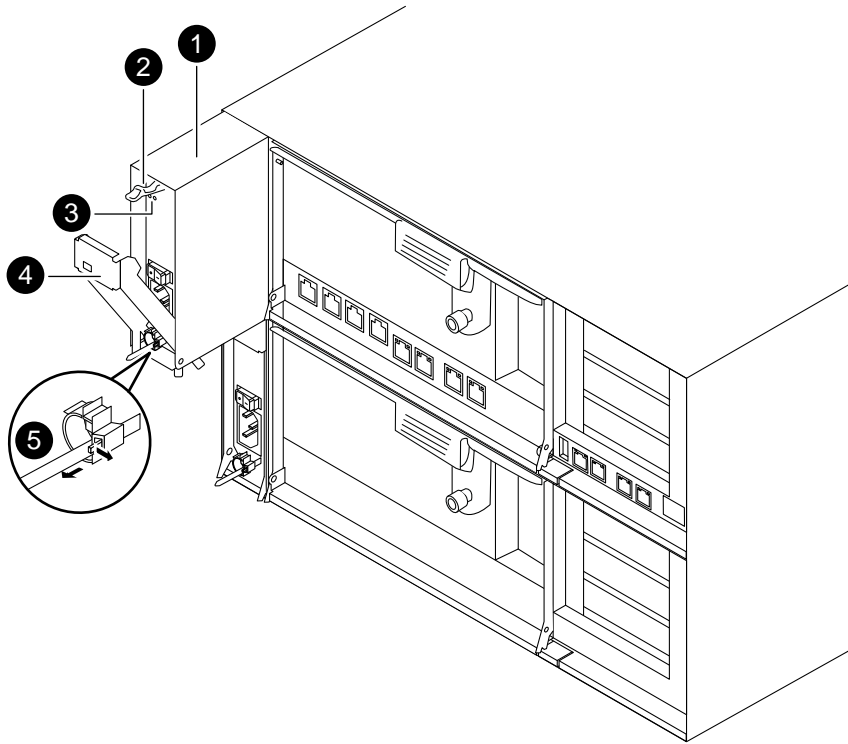

| | |
|----------|------------------------------|
| 1 | Power supply |
| 2 | Cam handle release latch |
| 3 | Power and Fault LEDs |
| 4 | Cam handle |
| 5 | Power cord locking mechanism |

- a. Pinch the tab on the locking mechanism of the cable retainer clip, and then open the retainer clip.
 - b. Slide the retainer clip off the cord.
 - c. Unplug the power cord from the power supply and the power source.
- 4.** Press down the release latch on the power supply cam handle, lower the cam handle to the fully open position, and then slide the power supply out of the chassis.

Make sure that you support the power supply with your free hand.

Installing a power supply

To install a power supply, you must place the power supply in the chassis, secure it, and reconnect the power cord to the power source.

Steps

1. Make sure that the on/off switch of the new power supply is in the Off position.
2. If you are not already grounded, properly ground yourself.
3. Insert the replacement power supply into the chassis by aligning it with the opening and gently pushing the power supply into the chassis.
4. Push firmly on the power supply cam handle to seat it all the way into the chassis, and then push the cam handle to the closed position, making sure that the cam handle release latch clicks into its locked position.
5. Reconnect the power cord and secure it to the power supply using the cable retaining clip.
6. Reconnect the power supply to the power source, and then turn it on.
The power supply should run with no fault LEDs lit and the green LED lit.
7. Reinstall the bezel.

Completing the replacement process

After you replace the part, you can return the failed part to NetApp, as described in the RMA instructions shipped with the kit. Contact technical support at , 888-463-8277 (North America), 00-800-44-638277 (Europe), or +800-800-80-800 (Asia/Pacific) if you need the RMA number or additional help with the replacement procedure.

Copyright information

Copyright © 2018 NetApp, Inc. All rights reserved. Printed in the U.S.

No part of this document covered by copyright may be reproduced in any form or by any means—graphic, electronic, or mechanical, including photocopying, recording, taping, or storage in an electronic retrieval system—without prior written permission of the copyright owner.

Software derived from copyrighted NetApp material is subject to the following license and disclaimer:

THIS SOFTWARE IS PROVIDED BY NETAPP "AS IS" AND WITHOUT ANY EXPRESS OR IMPLIED WARRANTIES, INCLUDING, BUT NOT LIMITED TO, THE IMPLIED WARRANTIES OF MERCHANTABILITY AND FITNESS FOR A PARTICULAR PURPOSE, WHICH ARE HEREBY DISCLAIMED. IN NO EVENT SHALL NETAPP BE LIABLE FOR ANY DIRECT, INDIRECT, INCIDENTAL, SPECIAL, EXEMPLARY, OR CONSEQUENTIAL DAMAGES (INCLUDING, BUT NOT LIMITED TO, PROCUREMENT OF SUBSTITUTE GOODS OR SERVICES; LOSS OF USE, DATA, OR PROFITS; OR BUSINESS INTERRUPTION) HOWEVER CAUSED AND ON ANY THEORY OF LIABILITY, WHETHER IN CONTRACT, STRICT LIABILITY, OR TORT (INCLUDING NEGLIGENCE OR OTHERWISE) ARISING IN ANY WAY OUT OF THE USE OF THIS SOFTWARE, EVEN IF ADVISED OF THE POSSIBILITY OF SUCH DAMAGE.

NetApp reserves the right to change any products described herein at any time, and without notice. NetApp assumes no responsibility or liability arising from the use of products described herein, except as expressly agreed to in writing by NetApp. The use or purchase of this product does not convey a license under any patent rights, trademark rights, or any other intellectual property rights of NetApp.

The product described in this manual may be protected by one or more U.S. patents, foreign patents, or pending applications.

RESTRICTED RIGHTS LEGEND: Use, duplication, or disclosure by the government is subject to restrictions as set forth in subparagraph (c)(1)(ii) of the Rights in Technical Data and Computer Software clause at DFARS 252.277-7103 (October 1988) and FAR 52-227-19 (June 1987).

Trademark information

NETAPP, the NETAPP logo, and the marks listed on the NetApp Trademarks page are trademarks of NetApp, Inc. Other company and product names may be trademarks of their respective owners.

<http://www.netapp.com/us/legal/netapptmlist.aspx>

How to send comments about documentation and receive update notifications

You can help us to improve the quality of our documentation by sending us your feedback. You can receive automatic notification when production-level (GA/FCS) documentation is initially released or important changes are made to existing production-level documents.

If you have suggestions for improving this document, send us your comments by email.

doccomments@netapp.com

To help us direct your comments to the correct division, include in the subject line the product name, version, and operating system.

If you want to be notified automatically when production-level documentation is released or important changes are made to existing production-level documents, follow Twitter account @NetAppDoc.

You can also contact us in the following ways:

- NetApp, Inc., 495 East Java Drive, Sunnyvale, CA 94089 U.S.
- Telephone: +1 (408) 822-6000
- Fax: +1 (408) 822-4501
- Support telephone: +1 (888) 463-8277